

INCH-POUND

RR-C-271G
28 March 2016
SUPERSEDING
RR-C-271F
5 July 2011

FEDERAL SPECIFICATION

CHAINS AND ATTACHMENTS, CARBON AND ALLOY STEEL

The General Services Administration has authorized the use of this federal specification by all federal agencies.

1. SCOPE AND CLASSIFICATION

1.1 Scope. This specification covers carbon and alloy steel chain of commercial quality together with the attachments most commonly used with this chain.

1.1.1 Federal specification coverage. Federal specifications do not include all types, grades, classes, and styles of the commodities indicated by the title of the specification, or which are commercially available, but are intended to cover the types that are suitable for Federal Government requirements.

1.2 Classification. The welded and weldless chain and attachments are of the following types, classes, grades and styles as specified below.

1.2.1 Chain types. The types, classes, grades and styles of welded and weldless chain are as follows (see 6.2):

Type I - Chain, welded steel (PIN code -C1)

Class 1 - Alloy chain (overhead lift)

Grade A – 80 grade

Grade B – 100 grade

Comments, suggestions, or questions on this document should be addressed to DLA Aviation, VEB, 8000 Jefferson Davis Highway, Richmond, VA 23297-5616 or e-mailed to STDZNMGT@dla.mil. Since contact information can change, you may want to verify the currency of this address information using the ASSIST database at <https://assist.dla.mil>.

AMSC N/A

FSC 4010

- Class 2 - High-test chain (grade 43)
- Class 3 - Transport chain (grade 70)
- Class 4 - Proof-coil chain (grade 30)
- Class 5 - Twist-link chain

- Style 1 - Long-link pattern (coil)
- Style 2 - Short-link pattern (machine)

Type II - Chain, weldless (PIN code -C2)

- Class 1 - Single-loop pattern chain
- Class 2 - Double-loop pattern chain
- Class 3 - Sash chain
- Class 4 - Flat-link chain
- Class 5 - Bead chain
- Class 6 - Plumber's chain
- Class 7 - Single-jack chain
- Class 8 - Double-jack chain
- Class 9 - Ladder chain
- Class 10 - Register chain
- Class 11 - Mechanical communication chain

1.2.2 Attachment types. Attachment types, grades, and classes are as follows (see 6.2):

Type II - Connecting links (PIN code -A2)

Type III - Lap links (PIN code -A3)

Type IVA - Anchor shackles (PIN code -A41)

Grade A - Regular

- Class 1 - Round pin and cotter
- Class 2 - Screw pin
- Class 3 - Bolt, nut and cotter

Grade B - High strength

- Class 1 - Round pin and cotter
- Class 2 - Screw pin
- Class 3 - Bolt, nut and cotter

Type IVB - Chain shackles (PIN code -A42)

Grade A - Regular

- Class 1 - Round pin and cotter
- Class 2 - Screw pin
- Class 3 - Bolt, nut and cotter

Grade B - High strength

- Class 1 - Round pin and cotter
- Class 2 - Screw pin
- Class 3 - Bolt, nut and cotter

Type V – Hooks (PIN code -A5)

Class 1 – Alloy hooks

Grade A – Grade 80

- Style 2E – Eye Grab hook (see 6.1.4.2)
- Style 2C – Clevis Grab hook (see 6.1.4.2)
- Style 3E – Eye Sling hook (see 6.1.4.1)
- Style 3C – Clevis Sling hook (see 6.1.4.1)

Grade B – Grade 100

- Style 2E – Eye Grab hook (see 6.1.4.2)
- Style 2C – Clevis Grab hook (see 6.1.4.2)
- Style 3E – Eye Sling hook (see 6.1.4.1)
- Style 3C – Clevis Sling hook (see 6.1.4.1)

Class 2 – High-test hooks (grade 43)

- Style 1E – Eye Slip hook (see 6.1.4.1)
- Style 1C – Clevis Slip hook (see 6.1.4.1)
- Style 2E – Eye Grab hook (see 6.1.4.2)
- Style 2C – Clevis Grab hook (see 6.1.4.2)

Class 3 – Transport hooks (grade 70)

- Style 1E – Eye Slip hook (see 6.1.4.1)
- Style 1C – Clevis Slip hook (see 6.1.4.1)
- Style 2E – Eye Grab hook (see 6.1.4.2)
- Style 2C – Clevis Grab hook (see 6.1.4.2)

Class 4 – Proof-coil hooks (grade 30)

- Style 1E – Eye Slip hook (see 6.1.4.1)
- Style 1C – Clevis Slip hook (see 6.1.4.1)
- Style 2E – Eye Grab hook (see 6.1.4.2)
- Style 2C – Clevis Grab hook (see 6.1.4.2)

RR-C-271G

Class 5 – Hoist hooks

Style 4E – Eye Hoist hook (see 6.1.4.3)

Style 4S – Swivel Eye Hoist hooks (see 6.1.4.3)

Class 6 – Barrel hooks

Type VI – Rings (PIN code -A6)

Type VII – Swivels (PIN code-A7)

Class 1 - Chain swivels

Class 2 - Eye and eye swivels

Class 3 - Jaw and eye swivels

Type IX - Bead chain fasteners (PIN code -A9)

Type X - Bead chain couplings (PIN code -A10)

Type XI - Bead chain insulating couplings (PIN code -A11)

Type XIII - Pear-shaped links (PIN code -A13)

Type XIV - Mechanical coupling links (PIN code -A14)

Grade A – 80 grade

Grade B – 100 grade

Type XV - End links (PIN code -A15)

Type XVI - Chain master links (PIN code -A16)

1.3 Part identification number (PIN). There are separate PIN configurations for each chain and chain attachment type. The complete PIN configuration is given in appendix A.

2. APPLICABLE DOCUMENTS

2.1 Government publications. The issues of the following documents, in effect on the date of invitation for bids or request for proposal, form a part of this specification to the extent specified herein.

Federal Standards

FED-STD-123

- Marking for Shipment (Civil Agencies)

Military Standard

- MIL-STD-1916 - DoD Preferred Methods for Acceptance of Product
- MIL-STD-2073-1 - Standard Practice for Military Packaging

(Copies of these documents are available online at <http://quicksearch.dla.mil>)

Federal Acquisition Regulation (FAR)

- Subpart 23.4 - Use of Recovered Materials and Biobased Products

(Copies of the FAR may be obtained online at <https://www.acquisition.gov>.)

2.2 Other publications. The following documents form a part of this specification to the extent specified herein. Unless a specific issue is identified, the issue in effect on the date of invitation for bids or request for proposal shall apply.

American Society for Quality (ASQ)

- ASQ H1331 - Zero Acceptance Number Sampling Plans

(Copies of this document are available online at <http://www.asq.org/>.)

ASME

- ASME B1.1 - Unified Inch Screw Threads (UN and UNR Thread Forms)

(Copies of this document are available online at <http://www.asme.org/>.)

ASTM International

- ASTM A143/A143M - Standard Practice for Safeguarding Against Embrittlement of Hot-Dip Galvanized Structural Steel Products and Procedure for Detecting Embrittlement
- ASTM A153/A153M - Standard Specification for Zinc Coating (Hot-Dip) on Iron and Steel Hardware
- ASTM A304 - Standard Specification for Carbon and Alloy Steel Bars Subject to End-Quench Hardenability Requirements
- ASTM A322 - Standard Specification for Steel Bars, Alloy, Standard Grades
- ASTM A391/A391M - Standard Specification for Grade 80 Alloy Steel Chain
- ASTM A413/A413M - Standard Specification for Carbon Steel Chain
- ASTM A466/A466M - Standard Specification for Weldless Chain

ASTM International (continued)

ASTM A467/A467M	- Standard Specification for Machine and Coil Chain
ASTM A510/A510M	- Standard Specification for General Requirements for Wire Rods and Coarse Round Wire, Carbon Steel
ASTM A576	- Standard Specification for Steel Bars, Carbon, Hot-Wrought, Special Quality
ASTM A752	- Standard Specification for General Requirements for Wire Rods and Coarse Round Wire, Alloy Steel
ASTM A909/A909M	- Standard Specification for Steel Forgings, Microalloy, for General Industrial Use
ASTM A920/A920M	- Standard Specification for Steel Bars, Microalloy, Hot-Wrought, Special Quality, Mechanical Properties
ASTM A921/A921M	- Standard Specification for Steel Bars, Microalloy, Hot-Wrought, Special Quality, for Subsequent Hot Forging
ASTM A952/A952M	- Standard Specification for Forged Grade 80 and Grade 100 Steel Lifting Components and Welded Attachment Links
ASTM A973/A973M	- Standard Specification for Grade 100 Alloy Steel Chain
ASTM B633	- Standard Specification for Electrodeposited Coatings of Zinc on Iron and Steel
ASTM B695	- Standard Specification for Coatings of Zinc Mechanically Deposited on Iron and Steel
ASTM D3951	- Standard Practice for Commercial Packaging

(Copies of this document are available online at <http://www.astm.org/>.)

2.3 Order of precedence. Unless otherwise noted herein or in the contract, in the event of a conflict between the text of this document and the references cited herein, the text of this document takes precedence. Nothing in this document, however, supersedes applicable laws and regulations unless a specific exemption has been obtained.

3. REQUIREMENTS

3.1 Material.

3.1.1 Applicable materials. All items specified in this document are listed in Appendix B with their applicable materials.

3.1.1.1 General. Unless otherwise specified, the material for type I chain and the indicated attachments and attachment parts shall conform to the chemical composition shown in table I.

TABLE I. Chemical composition.

Element	Maximum percent
Type I chain and type II, III, V, VI, VII, XIII, XIV, and XV attachments and attachment parts:	
Carbon	0.37 ¹
Phosphorus	0.05
Sulfur	0.05
Silicon	0.35
Type IV shackles:	
Carbon	0.45
Phosphorus	0.04
Sulfur	0.045
Silicon	0.35

¹ Steel with carbon 0.50 (maximum percent) is permitted for attachments or attachment parts provided the fabrication is done without welding.

3.1.2 Recovered materials. The offeror/contractor is encouraged to use recovered materials to the maximum extent practicable, in accordance with paragraph 23.403 of the Federal Acquisition Regulation (FAR).

3.2 Finish.

3.2.1 General. The finish for chain and attachments shall be as specified (see 6.2). The following finishes for chain and attachments are typical.

- (a) Self-colored (chain uncoated, attachments cleaned and uncoated) (PIN code S)
- (b) Bright finish (chain cleaned) (PIN code B)
- (c) Zinc-coated (PIN code Z)
- (d) Painted (PIN code P)

3.2.1.1 Type I, chain, welded steel.

3.2.1.1.1 Type I, class 1 chain. The finish for type I, class 1 shall be bright finish or painted.

3.2.1.1.2 Type I, class 2, 3, 4 and 5 chain. Unless otherwise specified (see 6.2), the finish for type I, class 2, 3, 4, and 5 shall be self-colored, bright finish, zinc coated or painted.

3.2.1.2 Type II, chain, weldless. Unless otherwise specified (see 6.2), the chain shall be zinc coated or self-colored.

3.2.1.3 Attachments. Unless otherwise specified (see 6.2), attachments shall be self-colored, painted or zinc coated.

3.2.1.4 Zinc coating. When zinc coating is specified, the coating may be applied by the hot-dip (galvanizing) process, by the electrodeposition process, or by the mechanically deposited coating process at the contractor's option. If the hot-dip process is used, the coating shall be applied in accordance with ASTM A153/A153M, class B3; if the electrodeposition process is used, it shall be in accordance with ASTM B633, type II, class Fe/Zn 12; and if the mechanically deposited coating process is used, it shall be in accordance with ASTM B695, type II, class 12. When the electrodeposition process is used, the coating shall be done on screw parts after threading and tapping is completed. When the hot-dip process is used, internal threads may be tapped or retapped after galvanizing. Zinc coating shall be adherent, smooth, and free from injurious defects.

3.2.1.4.1 Embrittlement. When zinc coating of alloy steel is specified, the safeguarding against embrittlement and the procedure for detecting embrittlement shall be in accordance with ASTM A143/A143M.

3.2.1.4.2 Paint over galvanizing. On attachments, paint may be applied over galvanizing at the option of the manufacturer. All other requirements of 3.2.1.4 shall be met.

3.3 Detail requirements - chain. The figures herein are descriptive, not restrictive, and are not intended to preclude the purchase of chain otherwise in accordance with this specification.

3.3.1 Type I, chain, welded steel.

3.3.1.1 Type I, class 1, welded steel alloy chain. The steel alloy chain shall be similar to figure 1 and shall be in accordance with ASTM A391/A391M for grade 80 or ASTM A973/A973M for grade 100.

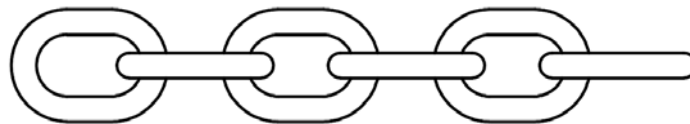

FIGURE 1. Type I, class 1, 2, 3, and 4 chain.

3.3.1.2 Type I, class 2, welded steel high-test chain. The high test chain shall be similar to figure 1 and shall be in accordance with ASTM A413/A413M, grade 43.

3.3.1.3 Type I, class 3, transport chain. The transport chain shall be similar to figure 1 and shall be in accordance with ASTM A413/A413M, grade 70.

3.3.1.4 Type I, class 4, welded steel proof-coil chain. The proof-coil chain shall be similar to figure 1 and shall be in accordance with ASTM A413/A413M, grade 30.

3.3.1.5 Type I, class 5, style 1, welded steel twist-link chain, long-link pattern (coil). The long-link chain shall be similar to figure 2 and shall conform to the dimensions and physical requirements specified in ASTM A467/A467M, class CT.



FIGURE 2. Type I, class 5, style 1, welded steel twist-link chain, long-link pattern (coil).

3.3.1.5.1 PIN designation for coil style twist-link chain. The PIN size designation for coil style twist-link chain shall be 01 to 04 for sizes 1 to 4 and 10 to 50 for trade sizes 1/0 to 5/0.

3.3.1.6 Type I, class 5, style 2, welded steel twist-link chain, short-link pattern (machine). The short-link chain shall be similar to figure 3 and shall be in accordance with the dimensions and physical requirements as specified in ASTM A467/A467M, class MT.

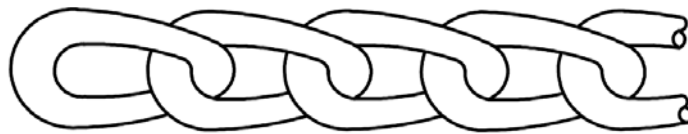

FIGURE 3. Type I, class 5, style 2, welded steel twist-link chain, short-link pattern (machine).

3.3.1.6.1 PIN designation for machine style twist-link chain. The PIN size designation for machine style twist-link chain shall be 01 to 04 for sizes 1 to 4 and 10 to 50 for trade sizes 1/0 to 5/0.

3.3.2 Type II, chain, weldless.

3.3.2.1 Class 1, single-loop pattern chain. The single-loop pattern chain shall be similar to figure 4 and shall be in accordance with ASTM A466/A466M, class SL.



FIGURE 4. Type II, class 1, weldless, single-loop pattern chain.

3.3.2.1.1 PIN size numbers for single-loop chain. The PIN size numbers for single-loop chain shall be 02 for trade size 2 and 10 through 50 for trade sizes 1/0 through 5/0.

3.3.2.2 Class 2, double-loop pattern chain. The double-loop pattern chain shall be similar to figure 5 and shall be in accordance with ASTM A466/A466M, class DL.



FIGURE 5. Type II, class 2, weldless double-loop pattern chain.

3.3.2.2.1 PIN size numbers for double-loop chain. The PIN size numbers for double-loop chain shall be 05 through 01 for trade size 5 through 1 and 10 through 80 for trade sizes 1/0 through 8/0 and shall include the L designation when required.

3.3.2.3 Class 3, sash chain. The sash chain shall be similar to figure 6 and shall be in accordance with ASTM A466/A466M, class SH.



FIGURE 6. Type II, class 3, weldless sash chain.

3.3.2.3.1 PIN size numbers for sash chain. The PIN size numbers for sash chain shall be the same as the trade size except a zero will be added before any single digit to create a 2 digit size number.

3.3.2.4 Class 4, flat-link chain. The flat-link chain shall be similar to figure 7 and shall be in accordance with the requirements as shown in table II.



FIGURE 7. Type II, class 4, weldless flat-link chain.

TABLE II. Type II, class 4, weldless flat-link chain.

Nominal metal thickness (inch)	Number of links per foot (approx)	Weight per 100 feet (approx) (pounds)		Breaking load (min) ¹ (pounds)		Trade number	PIN size number
		Steel	Brass	Steel	Brass		
0.083	8.5	16	17	1,600	1,120	2-0	02
0.065	17	12.5	13	990	695	113	11
0.103	9.75	35	37	2,190	1,535	210	21
0.125	9	40	42	3,240	2,270	280	28

¹ Maximum working load limit is 25 percent of breaking load.

3.3.2.5 Class 5, bead chain. The bead chain shall be similar to figure 8 and shall be in accordance with the requirements as shown in table III.

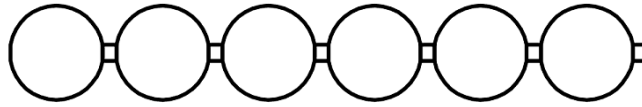

FIGURE 8. Type II, class 5, weldless bead chain.

TABLE III. Type II, class 5, weldless bead chain.

Nominal diameter of beads (approx) (inch)	Metal thickness (approx) (inch)	Number of beads per foot (approx)	Weight per 100 feet (approx) (pounds)	Breaking loads (min) ¹ (pounds)	Trade number	PIN size number
3/32	0.010	102	0.7	15	3	03
1/8	0.014	72	1.5	28	6	06
3/16	0.017	50	2.6	45	10	10
1/4	0.020	40	4.8	90	13	13
3/8	0.034	24	10.8	200	20	20

¹ Maximum working load limit is 25 percent of breaking load.

3.3.2.6 Class 6, plumber's chain. The plumber's chain shall be similar to figure 9 and shall be in accordance with ASTM A466/A466M, class SF.



FIGURE 9. Type II, class 6, weldless plumber's chain.

3.3.2.6.1 PIN size numbers for plumber's chain. The PIN size numbers for plumber's chain shall be 01 for trade size 1, 10 for trade size 1/0 and 20 for trade size 2/0.

3.3.2.7 Class 7, single-jack chain. The single-jack chain shall be similar to figure 10 and shall be in accordance with ASTM A466/A466M, class SJ.

FIGURE 10. Type II, class 7, weldless single-jack chain.

3.3.2.7.1 PIN size numbers for single-jack chain. The PIN size numbers for single-jack chain shall be the same as the trade size except a zero will be added before any single digit to create a 2 digit size number.

3.3.2.8 Class 8, double-jack chain. The double-jack chain shall be similar to figure 11 and shall be in accordance with ASTM A466/A466M, class DJ.

FIGURE 11. Type II, class 8, weldless double-jack chain.

3.3.2.8.1 PIN size numbers for double-jack chain. The PIN size numbers for double-jack chain shall be the same as the trade size.

3.3.2.9 Class 9, ladder chain. The ladder chain shall be similar to figure 12 and shall be in accordance with the requirements as shown in table IV.

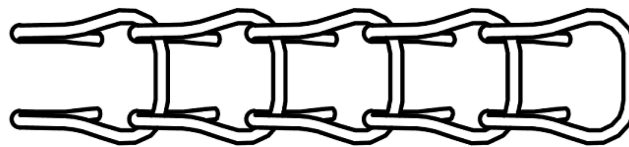
FIGURE 12. Type II, class 9, weldless ladder chain.TABLE IV. Type II, class 9, weldless ladder chain.

Nominal size of chain (inch)	Number of links per foot (approx) (also PIN size number)	Weight per 100 feet (approx) (pounds)	Breaking loads (min) ¹ (pounds)	
			Steel	Brass or bronze
0.036	64	0.8	45	40
0.048	42	2.5	70	60
0.055	34	3.5	85	75
0.080	25	6	145	130

¹Maximum working load limit is 25 percent of breaking load.

3.3.2.10 Class 10, register chain. The register chain shall be similar to figure 13 and shall be in accordance with ASTM A466/A466M, class RG.

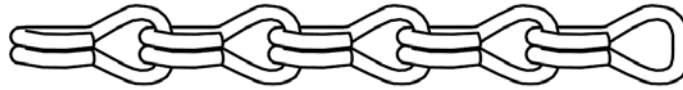

FIGURE 13. Type II, class 10, weldless register chain.

3.3.2.10.1 PIN size numbers for register chain. The PIN size numbers for register chain shall be the same as the trade size.

3.3.2.11 Class 11, mechanical communication chain. The mechanical communication chain shall be similar to figure 14 and shall be in accordance with the requirements as shown in table V.

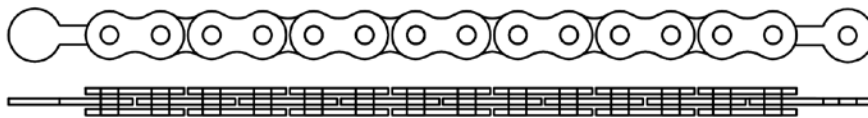

FIGURE 14. Type II, class 11, weldless mechanical communication chain.

TABLE V. Type II, class 11, weldless mechanical communication chain.

Nominal thickness outside links (inch)	Nominal thickness inside links (inch)	Width (max) (inch)	Pitch (center-to-center) of pins (approx)	Number of links per foot (approx)	Breaking load (min) ¹ (pounds)	PIN size number
1/16	1/8	0.25	0.375	32	800	01

¹Maximum working load limit is 25 percent of breaking load.

3.3.2.11.1 End links. Each end of the completed chain shall be fitted with a large brass link for the attachment of transmission wires.

3.3.2.11.2 Length. The total length of the finished chain shall be approximately 30 inches.

3.4 Detail requirements - attachments. The figures herein are descriptive, not restrictive, and are not intended to preclude the purchase of attachments otherwise in accordance with this specification.

3.4.1 Type II, connecting links. Connecting links shall be forged from carbon steel as specified in B.2.2.1, shall be similar to figure 15, and shall be in accordance with the dimensions and physical requirements as shown in table VI. The 3/16, 1/4, and 5/16-inch sizes shall have rivets only, no interlocking lugs.

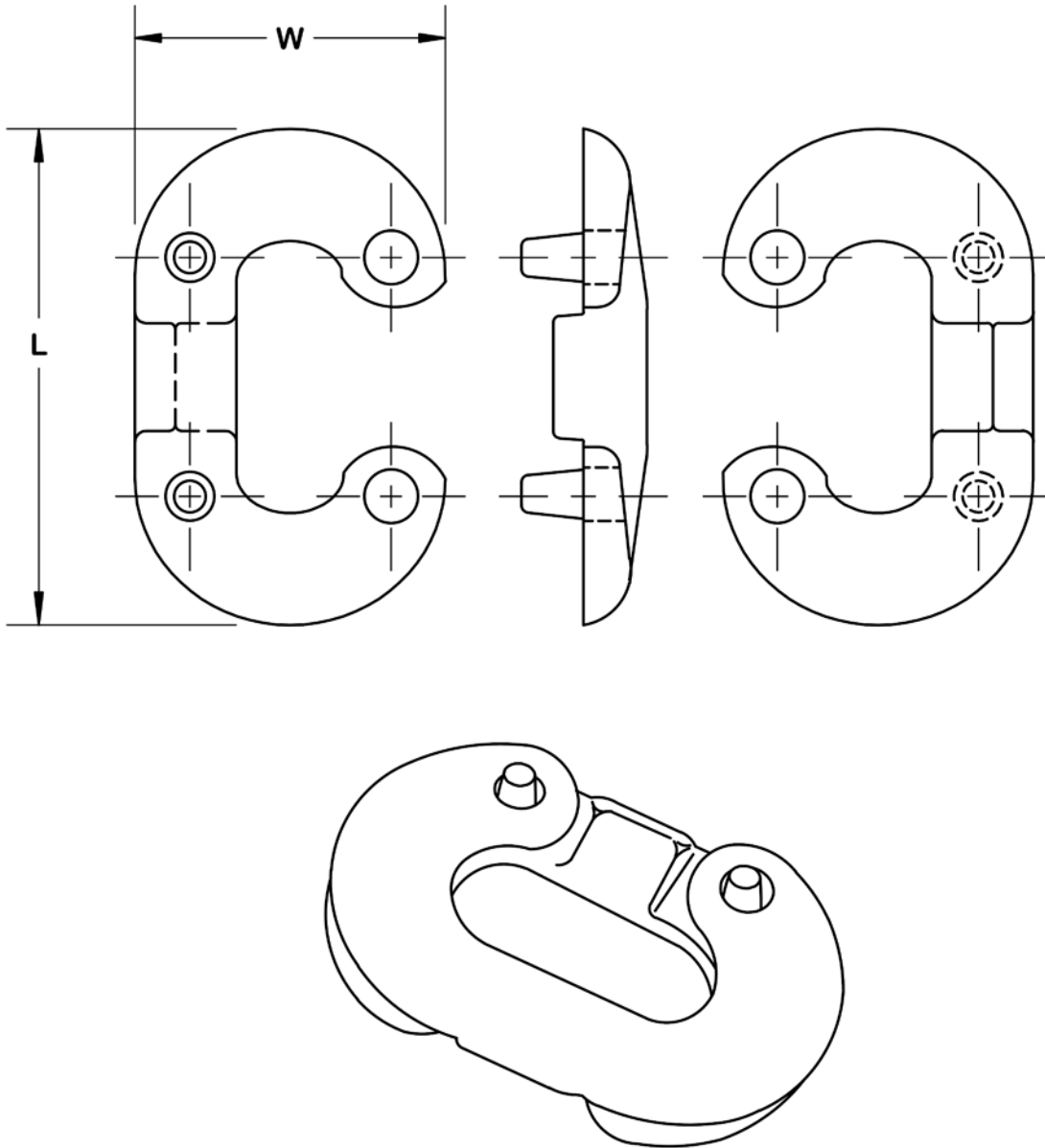

FIGURE 15. Type II, connecting links.

TABLE VI. Type II, connecting links.

Trade size (nom) (inch)	PIN size number	Outside dimensions of links (L x W) (approx.) (inches)	Weight per dozen (approx.) (pounds)	Working load limit (pounds)	Proof load (min) (pounds)	Breaking load (min) (pounds)
3/16	03	1.25 x 0.75	0.375	750	1,500	3,000
1/4	04	1.50 x 1.00	0.75	1,250	2,500	5,000
5/16	05	1.69 x 1.19	1	1,900	3,800	7,600
3/8	06	2.06 x 1.38	2	2,650	5,300	10,600
7/16	07	2.38 x 1.50	3.125	3,625	7,250	14,500
1/2	08	2.62 x 1.75	4.5	4,500	9,000	18,000
9/16	09	3.00 x 1.94	6.625	5,800	11,600	23,200
5/8	10	3.31 x 2.19	9	6,900	13,800	27,600
3/4	12	3.88 x 2.50	14.5	9,750	19,500	39,000
7/8	14	4.50 x 2.94	20.25	12,000	24,000	48,000
1	16	5.00 x 3.25	29	15,500	31,000	62,000
1-1/8	18	5.62 x 3.50	40	19,500	39,000	78,000
1-1/4	20	6.12 x 4.00	53.5	24,000	48,000	96,000
1-3/8	22	6.75 x 4.75	75	28,750	57,500	115,000
1-1/2	24	7.25 x 5.12	103	34,000	68,000	136,000
1-5/8	26	8.00 x 5.50	131	42,000	84,000	168,000
1-7/8	30	9.00 x 6.25	216	64,000	128,000	256,000

3.4.2 Type III, lap links. Lap links shall be formed from carbon steel as specified in B.2.2.2. Links shall be of the lap type, shall be similar to figure 16, and shall be in accordance with the dimensions and weights as shown in table VII.

FIGURE 16. Type III, lap link.

TABLE VII. Type III, lap links.

Diameter of metal (inches)	PIN size number	Length inside (nom) (inches)	Working load limit (pounds)	Weight per 100 links (approx) (pounds)	Breaking load (min) (pounds)
0.188	01	1.00	225	5	900
0.219	02	1.25	250	5.75	1,000
0.250	03	1.25	325	7.2	1,300
0.250	04	1.50	325	9	1,300
0.250	05	2.00	325	10.25	1,300
0.281	06	1.25	375	9.3	1,500
0.312	07	1.50	675	14.5	2,700
0.312	08	2.00	625	17	2,500
0.375	09	1.62	1,050	22	4,200
0.375	10	2.00	1,000	25	4,000
0.500	11	2.50	1,525	54	6,100

3.4.3 Type IV, shackles.

3.4.3.1 General. Type IVA and type IVB, grade A shackles shall be forged from carbon steel as specified in B.2.2.3. Pins and bolts for grade A shackles shall be made from carbon or alloy steel as specified in B.2.2.3.1 at the option of the manufacturer. Type IVA and type IVB, grade B shackles, together with their pins and bolts, shall be forged from alloy steel as specified in B.2.2.4.

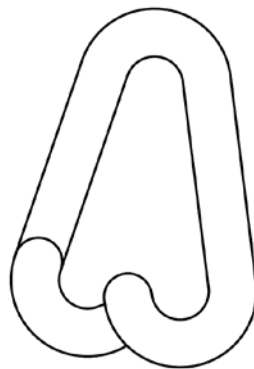
3.4.3.1.1 Threads. Screw-pin shackles shall be threaded after fabrication to final size and shape. Threads shall conform to ASME B1.1 for Unified Coarse (UNC/UNRC) threads unless the corresponding fine threads are specified (see 6.2). Threads on finished shackles shall be not looser than class 1 fit. The male threads of zinc-coated shackles may be undercut, as necessary, so that after coating they will properly mate (not less than class 1 fit) with the standard size female threads, or the inside threads may be similarly oversized.

3.4.3.1.2 Proof loads. Shackles shall withstand the proof loads shown in table VIII (see 4.4.2.2.1) without developing surface rupture or defects that would interfere with serviceability or prevent disassembly of the pin. After proof loading, screw-pin shackles shall be disassembled by hand after the first turn.

TABLE VIII. Mechanical properties.

Size (D) ⁽¹⁾ (nominal) (inches)	PIN size number	Working load limit (pounds)		Proof load (min) (pounds)		Breaking load (min) (pounds)	
		Grade A	Grade B	Grade A	Grade B	Grade A	Grade B
3/16	03	650	1,000	1,430	2,200	3,250	5,000
1/4	04	1,000	1,500	2,200	3,300	5,000	7,500
5/16	05	1,500	2,500	3,300	5,500	7,500	12,500
3/8	06	2,000	4,000	4,400	8,800	10,000	20,000
7/16	07	3,000	5,200	6,600	11,440	15,000	26,000
1/2	08	4,000	6,600	8,800	14,520	20,000	33,000
5/8	10	6,500	10,000	14,300	22,000	32,500	50,000
3/4	12	9,500	14,000	20,900	30,800	47,500	70,000
7/8	14	13,000	19,000	28,600	41,800	65,000	95,000
1	16	17,000	25,000	37,400	55,000	85,000	125,000
1-1/8	18	19,000	30,000	41,800	66,000	95,000	150,000
1-1/4	20	24,000	36,000	52,800	79,200	120,000	180,000
1-3/8	22	27,000	42,000	59,400	92,400	135,000	210,000
1-1/2 ⁽²⁾	24	34,000	50,000	74,800	110,000	170,000	250,000
1-1/2 ⁽³⁾	24	34,000	60,000	74,800	132,000	170,000	300,000
1-5/8 ⁽²⁾	26	40,000	58,000	88,000	127,600	200,000	290,000
1-5/8 ⁽³⁾	26	40,000	70,000	88,000	154,000	200,000	350,000
1-3/4 ⁽²⁾	28	50,000	68,000	110,000	149,600	250,000	340,000
1-3/4 ⁽³⁾	28	50,000	80,000	110,000	176,000	250,000	400,000
2 ⁽²⁾	32	70,000	86,000	154,000	189,200	350,000	430,000
2 ⁽³⁾	32	70,000	100,000	154,000	220,000	350,000	500,000
2-1/4 ⁽⁴⁾	36	80,000	120,000	176,000	264,000	400,000	600,000
2-1/2 ⁽⁴⁾	40	110,000	160,000	242,000	352,000	550,000	800,000
2-3/4 ⁽⁴⁾	44	120,000	180,000	264,000	396,000	600,000	900,000
3 ⁽⁴⁾	48	170,000	220,000	374,000	484,000	850,000	1,100,000
3-1/2 ⁽⁴⁾	56	240,000	280,000	528,000	616,000	1,200,000	1,400,000
4 ⁽⁴⁾	64	300,000	350,000	660,000	770,000	1,500,000	1,750,000

(1) – all classes unless noted

(2) – class 1, grade A and B and class 2, grade A and B

(3) - class 3, grade A and B

(4) – class 1, 2 and 3, grade A; class 3, grade B (no class 1 or 2 in grade B in sizes 2-1/4 and above)

3.4.3.1.3 Breaking loads. Shackles shall meet the breaking load requirements shown in table VIII (see 4.4.2.2.2).

3.4.3.1.4 Working load limit. The working load limits (WLL) of shackles covered by this specification are shown in table VIII.

3.4.3.1.5 Ductility. Shackles shall be sufficiently ductile so that, when fractured, the fractured member shall show a permanent distortion before breaking. If the pin fractures, it shall show a permanent bend of not less than 20 degrees. If the body fractures, it shall show a permanent mid-shackle set of not less than 15 percent of the original spread between bows.

3.4.3.1.6 Marking. Each shackle body shall be permanently and legibly marked in raised or stamped letters on the side of the shackle bow with the identifying manufacturer's name or trademark, shackle size, and the WLL. As a minimum, all shackle pins and bolts shall be marked with the manufacturer's mark or symbol; in addition, all grade B shackle pins and bolts shall be marked with the raised or stamped letters "HS" on the head. Shackle markings shall be raised or stamped letters or figures of the maximum practical height permitted by the size of the shackle component being marked, but not to exceed 0.75 inch in height by 0.125 inch in relief. Stamping dies shall be of the round bottom, low-stress type. Marking location shall not interfere with the serviceability of the shackle assembly.

3.4.3.1.7 Finish. Shackle components shall be as specified in 3.2.1.3.

3.4.3.2 Form and dimensions. The form of the respective shackle types and classes shall be similar to that shown on figures 17 and 18 (see 6.2). Except for reference dimensions, the dimensions of shackle bodies and component pins and bolts shall conform to the dimensional requirements specified in tables IX, X, XI, XII, XIII, and XIV. Reference dimensions are for information only.

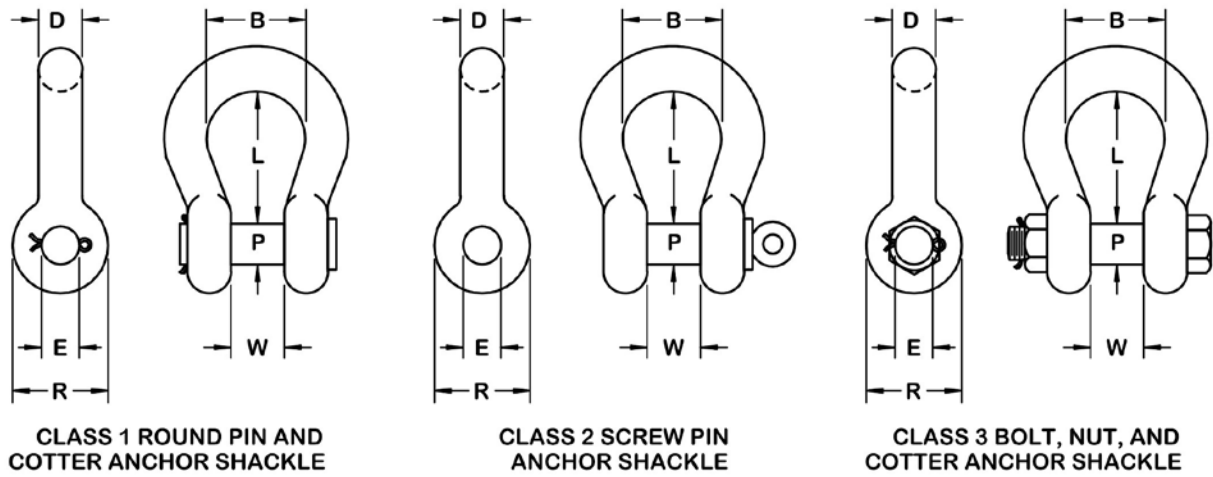

FIGURE 17. Type IVA, anchor shackles.

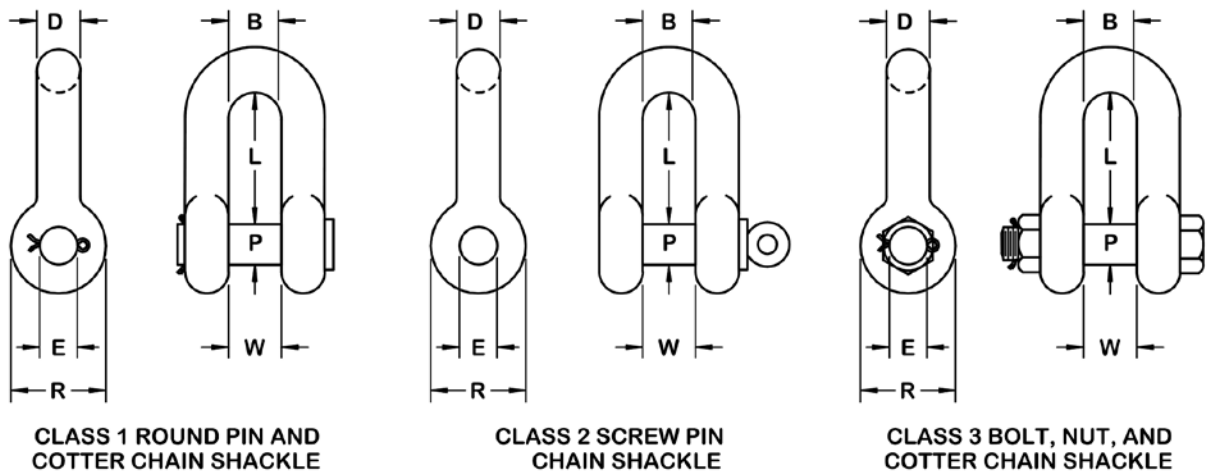

FIGURE 18. Type IVB, chain shackles.

TABLE IX. Type IVA, class 1, round pin and cotter anchor shackles.

Trade size (nom) (inches)	Dimension (D) (min) (inches)	Diameter pin (P) (min) (inches)	Diameter inside eye (E) (ref) (inches)	Width between eyes (W) ± nominal tolerance (inches)	Length inside (L) ± nominal tolerance (inches)	Width bow (B) (min) (inches)	Diameter outside eye (R) (max) (inches)	Weight per 100 shackles (approx) (pounds)
3/16	0.18	0.24	0.29	0.38 ±0.13	0.88 ±0.06	0.56	0.63	5
1/4	0.24	0.30	0.40	0.47 ±0.13	1.13 ±0.06	0.75	0.88	12
5/16	0.30	0.37	0.47	0.53 ±0.13	1.25 ±0.06	0.81	1.00	18
3/8	0.36	0.43	0.53	0.66 ±0.13	1.44 ±0.13	0.93	1.13	30
7/16	0.42	0.49	0.59	0.75 ±0.13	1.69 ±0.13	1.06	1.25	49
1/2	0.48	0.61	0.72	0.81 ±0.13	1.88 ±0.13	1.18	1.38	74
5/8	0.59	0.73	0.84	1.06 ±0.13	2.38 ±0.13	1.50	1.88	144
3/4	0.71	0.85	0.97	1.25 ±0.13	2.81 ±0.25	1.75	2.13	216
7/8	0.83	0.98	1.09	1.44 ±0.13	3.31 ±0.25	2.00	2.38	337
1	0.95	1.10	1.22	1.69 ±0.13	3.75 ±0.25	2.31	2.63	530
1-1/8	1.07	1.22	1.34	1.81 ±0.13	4.25 ±0.25	2.62	2.88	700
1-1/4	1.19	1.34	1.47	2.03 ±0.13	4.69 ±0.25	2.87	3.25	960
1-3/8	1.31	1.46	1.62	2.25 ±0.19	5.25 ±0.25	3.25	3.50	1,260
1-1/2	1.42	1.58	1.75	2.38 ±0.19	5.75 ±0.25	3.37	3.75	1,730
1-5/8	1.54	1.71	1.87	2.62 ±0.19	6.25 ±0.25	4.00	4.13	2,200
1-3/4	1.66	1.95	2.15	2.88 ±0.19	7.00 ±0.25	4.50	4.50	2,780
2	1.90	2.19	2.40	3.25 ±0.19	7.75 ±0.50	5.25	5.25	4,110
2-1/4	2.14	2.44	2.65	3.88 ±0.19	9.25 ±0.50	5.50	5.75	5,600
2-1/2	2.38	2.68	2.90	4.12 ±0.25	10.50 ±0.50	6.75	6.25	8,350
3	2.85	3.17	3.40	5.00 ±0.25	13.00 ±0.75	7.37	6.75	11,900
3-1/2	3.32	3.66	3.90	5.25 ±0.25	15.00 ±0.75	9.00	8.50	21,200
4	3.80	4.14	4.40	5.50 ±0.25	14.50 ±0.75	10.50	9.50	30,500

TABLE X. Type IVA, class 2, screw pin anchor shackles.

Trade size (nom) (inches)	Dimension (D) (min) (inch)	Diameter pin (P) (min) (inches)	Diameter unthreaded eye (E) (ref) (inches)	Width between eyes (W) ± nom tolerance (inches)	Length inside (L) ± nom tolerance (inches)	Width bow (B) (min) (inches)	Major dia. threaded eye (ref) (inches)	Dia. outside eye (R) (max) (inches)	Weight per 100 shackles (approx) (pounds)
3/16	0.18	0.24	0.31	0.38 ±0.13	0.88 ±0.06	0.56	0.281	0.63	5
1/4	0.24	0.30	0.40	0.47 ±0.13	1.13 ±0.06	0.75	0.344	0.88	12
5/16	0.30	0.37	0.47	0.53 ±0.13	1.25 ±0.06	0.81	0.406	1.00	18
3/8	0.36	0.43	0.53	0.66 ±0.13	1.44 ±0.13	0.93	0.469	1.12	30
7/16	0.42	0.49	0.59	0.75 ±0.13	1.69 ±0.13	1.06	0.531	1.25	49
1/2	0.48	0.61	0.72	0.81 ±0.13	1.88 ±0.13	1.18	0.656	1.37	74
5/8	0.59	0.73	0.84	1.06 ±0.13	2.38 ±0.13	1.50	0.781	1.87	144
3/4	0.71	0.85	0.97	1.25 ±0.13	2.81 ±0.25	1.75	0.906	2.12	216
7/8	0.83	0.98	1.09	1.44 ±0.13	3.31 ±0.25	2.00	1.031	2.37	337
1	0.95	1.10	1.22	1.69 ±0.13	3.75 ±0.25	2.31	1.156	2.62	530
1-1/8	1.07	1.22	1.34	1.81 ±0.13	4.25 ±0.25	2.62	1.297	2.87	700
1-1/4	1.19	1.34	1.47	2.03 ±0.13	4.69 ±0.25	2.87	1.422	3.25	960
1-3/8	1.31	1.46	1.62	2.25 ±0.19	5.25 ±0.25	3.25	1.547	3.50	1,260
1-1/2	1.42	1.58	1.75	2.38 ±0.19	5.75 ±0.25	3.37	1.672	3.75	1,730
1-5/8	1.54	1.71	1.87	2.62 ±0.19	6.25 ±0.25	4.00	1.797	4.12	2,200
1-3/4	1.66	1.95	2.15	2.88 ±0.19	7.00 ±0.25	4.50	2.047	4.50	2,780
2	1.90	2.19	2.40	3.25 ±0.19	7.75 ±0.50	5.25	2.297	5.25	4,110
2-1/4	2.14	2.44	2.65	3.88 ±0.19	9.25 ±0.50	5.50	2.547	5.75	5,600
2-1/2	2.38	2.68	2.90	4.12 ±0.25	10.50 ±0.50	6.75	2.797	6.25	8,350
3	2.85	3.17	3.40	5.00 ±0.25	13.00 ±0.75	7.37	3.297	6.75	11,900
3-1/2	3.32	3.66	3.90	5.25 ±0.25	15.00 ±0.75	9.00	3.797	8.50	21,200
4	3.80	4.14	4.40	5.50 ±0.25	14.50 ±0.75	10.50	4.297	9.50	30,500

TABLE XI. Type IVA, class 3, bolt, nut and cotter anchor shackles.

Trade size (nom) (inches)	Dimension (D) (min) (inch)	Diameter bolt (P) (min) (inches)	Diameter inside eye (E) (ref) (inches)	Width between eyes (W) ± nom tolerance (inches)	Length inside (L) ± nom tolerance (inches)	Width bow (B) (min) (inches)	Diameter outside eye (R) (max) (inches)	Weight per 100 shackles (approx) (pounds)
3/16	0.18	0.24	0.29	0.38 ±0.13	0.88 ±0.06	0.56	0.63	5
1/4	0.24	0.30	0.40	0.47 ±0.13	1.13 ±0.06	0.75	0.88	12
5/16	0.30	0.36	0.47	0.53 ±0.13	1.25 ±0.06	0.81	1.00	18
3/8	0.36	0.43	0.53	0.66 ±0.13	1.44 ±0.13	0.93	1.13	30
7/16	0.42	0.49	0.59	0.75 ±0.13	1.69 ±0.13	1.06	1.25	49
1/2	0.48	0.61	0.72	0.81 ±0.13	1.88 ±0.13	1.18	1.38	82
5/8	0.59	0.73	0.84	1.06 ±0.13	2.38 ±0.13	1.50	1.88	158
3/4	0.71	0.85	0.97	1.25 ±0.13	2.82 ±0.25	1.75	2.13	280
7/8	0.83	0.98	1.09	1.44 ±0.13	3.31 ±0.25	2.00	2.38	395
1	0.95	1.10	1.22	1.69 ±0.13	3.75 ±0.25	2.31	2.63	560
1-1/8	1.07	1.22	1.34	1.81 ±0.13	4.25 ±0.25	2.62	2.88	785
1-1/4	1.19	1.34	1.47	2.03 ±0.13	4.69 ±0.25	2.87	3.25	1,120
1-3/8	1.31	1.46	1.62	2.25 ±0.19	5.25 ±0.25	3.25	3.50	1,520
1-1/2	1.42	1.58	1.75	2.38 ±0.19	5.75 ±0.25	3.37	3.75	1,950
1-5/8	1.54	1.71	1.87	2.62 ±0.19	6.25 ±0.25	4.00	4.13	2,410
1-3/4	1.66	1.95	2.15	2.88 ±0.19	7.00 ±0.25	4.50	4.50	3,130
2	1.90	2.19	2.40	3.25 ±0.19	7.75 ±0.50	5.25	5.25	4,630
2-1/4	2.14	2.44	2.65	3.88 ±0.19	9.25 ±0.50	5.50	5.75	5,650
2-1/2	2.38	2.68	2.90	4.12 ±0.25	10.50 ±0.50	6.75	6.25	9,400
3	2.85	3.17	3.40	5.00 ±0.25	13.00 ±0.75	7.37	6.75	14,500
3-1/2	3.32	3.66	3.90	5.25 ±0.25	15.00 ±0.75	9.00	8.50	26,500
4	3.80	4.14	4.40	5.50 ±0.25	14.50 ±0.75	10.50	9.50	35,800

TABLE XII. Type IVB, class 1, round pin and cotter chain shackles.

Trade size (nom) (inches)	Dimension (D) (min) (inch)	Diameter pin (P) (min) (inches)	Diameter inside eye (E) (ref) (inches)	Width between eyes (W) \pm nom tolerance (inches)	Length inside (L) \pm nom tolerance (inches)	Diameter outside eye (R) (max) (inches)	Weight per 100 shackles (approx) (pounds)
3/16	0.18	0.24	0.31	0.38 \pm 0.13	0.75 \pm 0.06	0.63	5
1/4	0.24	0.30	0.40	0.47 \pm 0.13	0.88 \pm 0.06	0.88	11
5/16	0.30	0.37	0.47	0.53 \pm 0.13	1.03 \pm 0.06	1.00	17
3/8	0.36	0.43	0.53	0.66 \pm 0.13	1.25 \pm 0.13	1.13	28
7/16	0.42	0.49	0.59	0.75 \pm 0.13	1.44 \pm 0.13	1.25	42
1/2	0.48	0.61	0.72	0.81 \pm 0.13	1.62 \pm 0.13	1.38	68
5/8	0.59	0.73	0.84	1.06 \pm 0.13	2.00 \pm 0.13	1.88	121
3/4	0.71	0.85	0.97	1.25 \pm 0.13	2.38 \pm 0.25	2.13	214
7/8	0.83	0.98	1.09	1.44 \pm 0.13	2.81 \pm 0.25	2.38	310
1	0.95	1.10	1.22	1.69 \pm 0.13	3.19 \pm 0.25	2.63	450
1-1/8	1.07	1.22	1.34	1.81 \pm 0.13	3.56 \pm 0.25	2.88	660
1-1/4	1.19	1.34	1.47	2.03 \pm 0.13	3.94 \pm 0.25	3.25	890
1-3/8	1.31	1.46	1.62	2.25 \pm 0.19	4.44 \pm 0.25	3.50	1,200
1-1/2	1.42	1.58	1.75	2.38 \pm 0.19	4.88 \pm 0.25	3.75	1,620
1-5/8	1.54	1.71	1.88	2.62 \pm 0.19	5.25 \pm 0.25	4.13	2,020
1-3/4	1.66	1.95	2.15	2.88 \pm 0.19	5.75 \pm 0.25	4.50	2,500
2	1.90	2.19	2.40	3.25 \pm 0.19	6.75 \pm 0.50	5.25	3,600
2-1/4	2.14	2.44	2.65	3.88 \pm 0.19	7.13 \pm 0.50	5.75	5,000
2-1/2	2.38	2.68	2.90	4.13 \pm 0.25	8.00 \pm 0.50	6.25	7,400
3	2.85	3.17	3.40	5.00 \pm 0.25	9.00 \pm 0.75	6.75	10,600
3-1/2	3.32	3.66	3.90	5.25 \pm 0.25	10.50 \pm 0.75	8.50	18,900
4	3.80	4.14	4.40	5.50 \pm 0.25	12.00 \pm 0.75	9.50	27,100

TABLE XIII. Type IVB, class 2, screw pin chain shackles.

Trade size (nom) (inches)	Dimension (D) (min) (inch)	Diameter pin (P) (min) (inches)	Diameter unthreaded eye (E) (ref) (inches)	Width between eyes (W) \pm nom tolerance (inches)	Length inside (L) \pm nom tolerance (inches)	Major dia. threaded eye (ref) (inches)	Dia. outside eye (R) (max) (inches)	Weight per 100 shackles (approx) (pounds)
3/16	0.18	0.24	0.31	0.38 \pm 0.13	0.75 \pm 0.06	0.281	0.63	5
1/4	0.24	0.30	0.40	0.47 \pm 0.13	0.88 \pm 0.06	0.344	0.88	11
5/16	0.30	0.37	0.47	0.53 \pm 0.13	1.03 \pm 0.06	0.406	1.00	17
3/8	0.36	0.43	0.53	0.66 \pm 0.13	1.13 \pm 0.13	0.469	1.25	28
7/16	0.42	0.49	0.59	0.75 \pm 0.13	1.44 \pm 0.13	0.531	1.25	42
1/2	0.48	0.61	0.72	0.81 \pm 0.13	1.63 \pm 0.13	0.656	1.38	68
5/8	0.59	0.73	0.84	1.06 \pm 0.13	2.00 \pm 0.13	0.781	1.88	121
3/4	0.71	0.85	0.97	1.25 \pm 0.13	2.38 \pm 0.25	0.906	2.13	214
7/8	0.83	0.98	1.09	1.44 \pm 0.13	2.81 \pm 0.25	1.031	2.38	310
1	0.95	1.10	1.22	1.69 \pm 0.13	3.19 \pm 0.25	1.156	2.63	450
1-1/8	1.07	1.22	1.34	1.81 \pm 0.13	3.56 \pm 0.25	1.297	2.88	660
1-1/4	1.19	1.34	1.47	2.03 \pm 0.13	3.94 \pm 0.25	1.422	3.25	890
1-3/8	1.31	1.46	1.62	2.25 \pm 0.19	4.44 \pm 0.25	1.547	3.50	1,200
1-1/2	1.42	1.58	1.75	2.38 \pm 0.19	4.88 \pm 0.25	1.672	3.75	1,620
1-5/8	1.54	1.71	1.88	2.63 \pm 0.19	5.25 \pm 0.25	1.797	4.13	2,020
1-3/4	1.66	1.95	2.15	2.88 \pm 0.19	5.75 \pm 0.25	2.047	4.50	2,500
2	1.90	2.19	2.40	3.25 \pm 0.19	6.75 \pm 0.50	2.297	5.25	3,600
2-1/4	2.14	2.44	2.65	3.88 \pm 0.19	7.13 \pm 0.50	2.547	5.75	5,000
2-1/2	2.38	2.68	2.90	4.13 \pm 0.25	8.00 \pm 0.50	2.797	6.25	7,400
3	2.85	3.17	3.40	5.00 \pm 0.25	9.00 \pm 0.75	3.297	6.75	10,600
3-1/2	3.32	3.66	3.90	5.25 \pm 0.25	10.50 \pm 0.75	3.797	8.50	18,900
4	3.80	4.14	4.40	5.50 \pm 0.25	12.00 \pm 0.75	4.297	9.50	27,100

TABLE XIV. Type IVB, class 3, bolt, nut and cotter chain shackles.

Trade size (nom) (inches)	Dimension (D) (min) (inch)	Diameter bolt (P) (min) (inches)	Diameter inside eye (E) (ref) (inches)	Width between eyes (W) (inches)	Length inside (L) (inches)	Diameter outside eye (R) (max) (inches)	Weight per 100 shackles (approx) (pounds)
3/16	0.18	0.24	0.31	0.38 ±0.13	0.75 ±0.06	0.63	5
1/4	0.24	0.30	0.40	0.47 ±0.13	0.88 ±0.06	0.88	11
5/16	0.30	0.36	0.47	0.53 ±0.13	1.03 ±0.06	1.00	17
3/8	0.36	0.43	0.53	0.66 ±0.13	1.25 ±0.13	1.13	28
7/16	0.42	0.49	0.59	0.75 ±0.13	1.44 ±0.13	1.25	42
1/2	0.48	0.61	0.72	0.81 ±0.13	1.63 ±0.13	1.38	76
5/8	0.59	0.73	0.84	1.06 ±0.13	2.00 ±0.13	1.88	156
3/4	0.71	0.85	0.97	1.25 ±0.13	2.38 ±0.25	2.13	262
7/8	0.83	0.98	1.09	1.44 ±0.13	2.81 ±0.25	2.38	365
1	0.95	1.10	1.22	1.69 ±0.13	3.19 ±0.25	2.63	535
1-1/8	1.07	1.22	1.34	1.81 ±0.13	3.56 ±0.25	2.88	727
1-1/4	1.19	1.34	1.47	2.03 ±0.13	3.94 ±0.25	3.25	1,020
1-3/8	1.31	1.46	1.63	2.25 ±0.19	4.44 ±0.25	3.50	1,335
1-1/2	1.42	1.58	1.75	2.38 ±0.19	4.88 ±0.25	3.75	1,850
1-5/8	1.54	1.71	1.88	2.63 ±0.19	5.25 ±0.25	4.13	2,310
1-3/4	1.66	1.95	2.15	2.88 ±0.19	5.75 ±0.25	4.50	2,850
2	1.90	2.19	2.40	3.25 ±0.19	6.75 ±0.50	5.25	4,110
2-1/2	2.38	2.68	2.90	4.13 ±0.25	8.00 ±0.50	6.25	8,450
3	2.85	3.17	3.40	5.00 ±0.25	9.00 ±0.75	6.75	12,300
3-1/2	3.32	3.66	3.90	5.25 ±0.25	10.50 ±0.75	8.50	21,800
4	3.80	4.14	4.40	5.50 ±0.25	12.00 ±0.75	9.50	31,000

3.4.4 Type V, Hooks. The hook bodies shall be forged. Class 1, 5 and 6 hooks shall be forged from alloy steel as specified in B.2.2.5.1. Class 2 and 4 hooks shall be forged from carbon steel as specified in B.2.2.5.2. Class 3 hooks shall be forged from carbon steel or alloy steel as specified in B.2.2.5.3. Refer to section 1.2, Type V – Hooks, for listed class, grade and style combinations.

3.4.4.1 Ductility. Hooks shall be sufficiently ductile so that, when fractured, the fractured member shall show a permanent distortion before breaking. The throat opening shall show a permanent bend of not less than 15 degrees.

3.4.4.2 Finish. Hooks shall be finished as specified in 3.2.1.3.

3.4.4.3 Hook styles. Hooks shall be of one of the following styles.

3.4.4.3.1 Class 1 through 4, style 1 slip hook and style 3 sling hooks. For use to connect a chain to a load. Style 1 is for use when connecting to a chain sling and style 3 is for use when connecting to a fabric sling. Basic hook configuration shall be similar to figure 19 (a) or (b) as specified.

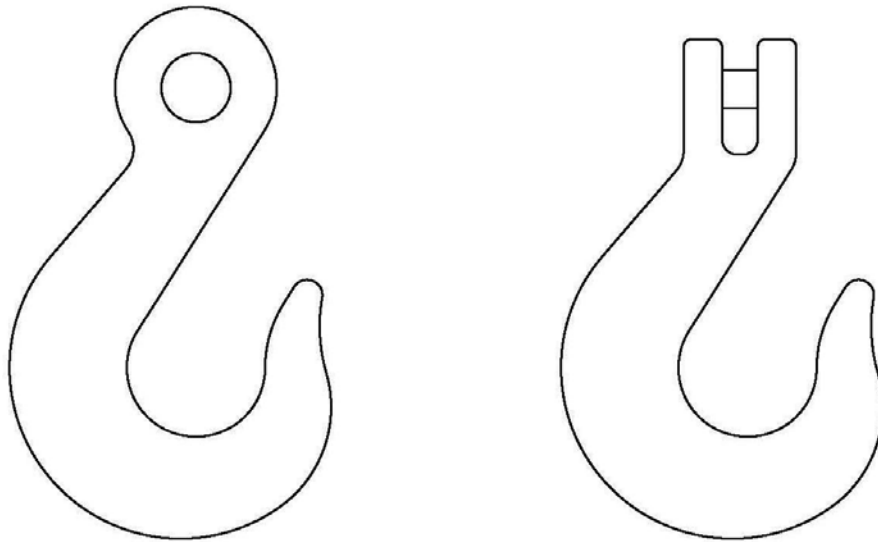

(a) Eye attachment (style 1E and 3E) (b) Clevis attachment (style 3C and 3C)

Figure 19. Basic hook design – slip and sling hooks
Actual design at manufacturer's option

3.4.4.3.2 Class 1 through 4, style 2 grab hook. For use to attach to a chain at a specific link. Basic hook configuration shall be similar to figure 20

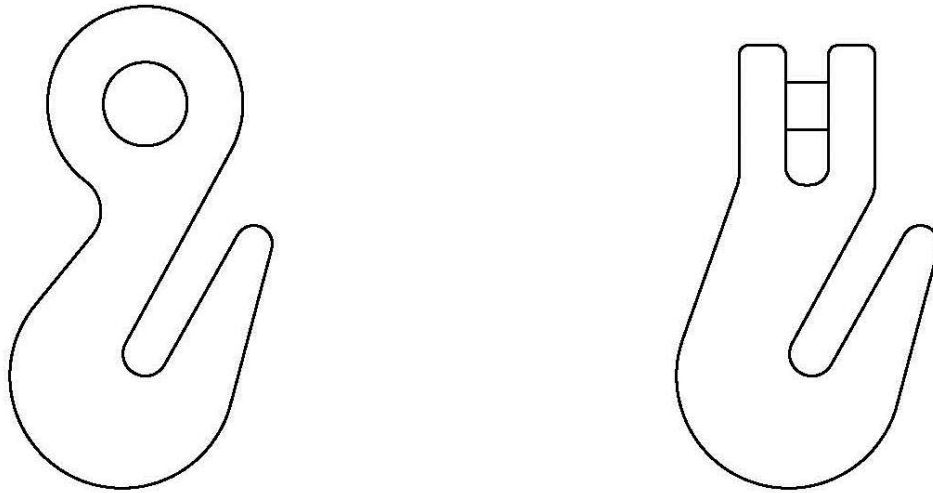

(a) Eye attachment (style 2E)

(b) Clevis attachment (style 2C)

Figure 20. Basic hook design – grab hook
Actual design at manufacturer's option

3.4.4.3.3 Class 5 hoist hooks. Typically for use with wire rope, not chain and to connect to the load. Basic hook configuration shall be similar to figure 21

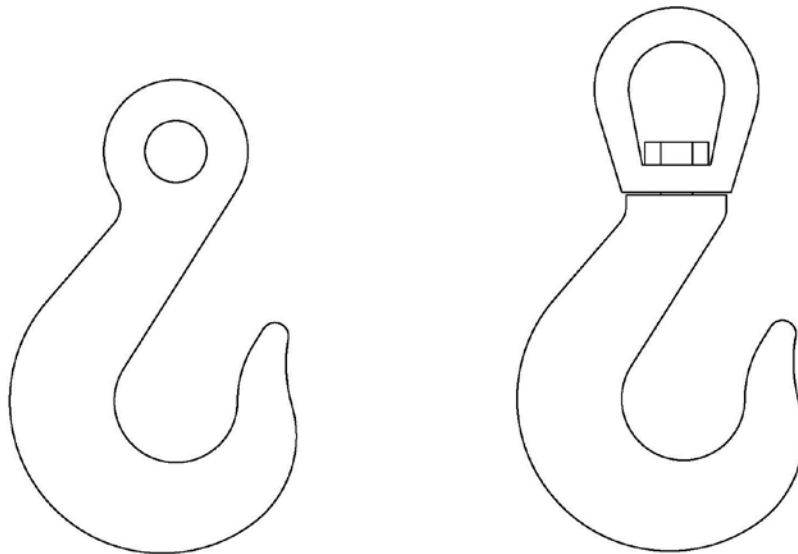

(a) Eye attachment (style 4E)

(b) Clevis attachment (style 4C)

Figure 21. Basic hook design – hoist hooks
Actual design at manufacturer's option

3.4.4.3.4 Class 6 barrel hooks. Eye barrel hooks shall be similar to figure 22 and shall have a nominal overall length of 5 inches.

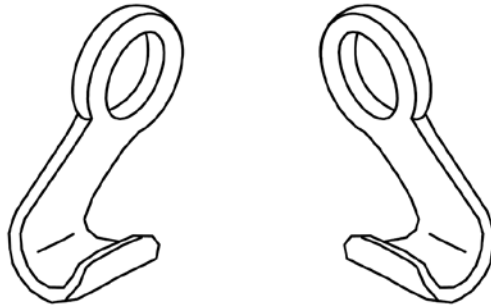

FIGURE 22. Type V, class 6, eye barrel hook.

3.4.4.4 Attachment. Hook attachment shall be an integral eye or clevis or a swivel eye as shown in figures 19, 20 and 21 except class 6 which shall have an eye as shown in figure 22

3.4.4.5 Mechanical requirements. Hooks shall meet the following minimum mechanical requirements.

3.4.4.5.1 Class 1, grade A and B hooks. All styles of class 1 hooks shall meet the mechanical requirements of ASTM A952/A952M. Grade A hooks shall conform to grade 80 requirements and grade B shall conform to grade 100 requirements.

3.4.4.5.2 Class 2 hooks. All styles of class 2 hooks shall meet the mechanical requirements of ASTM A413/A413M, grade 43 chain.

3.4.4.5.3 Class 3 hooks. All styles of class 2 hooks shall meet the mechanical requirements of ASTM A413/A413M, grade 70 chain.

3.4.4.5.4 Class 4 hooks. All styles of class 2 hooks shall meet the mechanical requirements of ASTM A413/A413M, grade 30 chain.

3.4.4.5.5 Class 5 hooks. All styles of class 5 hooks shall meet or exceed the mechanical requirements of table XV.

TABLE XV. Mechanical requirements for type V, class 5 hoist hooks.

Hook Size	PIN Size Number	Working Load Limit (pounds)	Proof Load (min) (pounds)	Breaking Load (min) (pounds)
1 ton	010	2,000	4,000	8,000
1.5 ton	015	3,000	6,000	12,000
2 ton	020	4,000	8,000	16,000
3 ton	030	6,000	12,000	24,000
4.5 ton	045	9,000	18,000	36,000
7 ton	070	14,000	28,000	56,000
11 ton	110	22,000	44,000	88,000
15 ton	150	30,000	60,000	120,000
22 ton	220	44,000	88,000	176,000
30 ton	300	60,000	120,000	240,000
37 ton	370	74,000	148,000	296,000

3.4.4.5.6 Class 6 hooks. Class 6 hooks shall withstand a proof load of 5,500 pounds.

3.4.5 Type VI, rings. The rings shall be forged or welded from alloy steel as specified in B.2.2.6. The rings shall be heat treated, be similar to figure 23, and shall be accordance with the sizes and weights as shown in table XVI.

FIGURE 23. Type VI, ring.

TABLE XVI. Type VI, rings.

Diameter stock (D) (nom) (inches)	Inside diameter (ID) (nom) (inches)	PIN size number	Weight each (approx) (pounds)	Working load limit (pounds)	Proof load (min) (pounds)	Breaking load (min) (pounds)
0.75	4	41	1.8	6,400	12,800	38,400
0.875	4	42	2.6	7,200	14,400	43,200
0.875	5.5	52	3.4	5,600	11,200	33,600
1	4	43	3.5	10,800	21,600	64,800
1.125	6	64	6.5	10,400	20,800	62,400
1.25	7	75	6.8	17,000	34,000	102,000
1.375	6	66	10.38	19,000	38,000	114,000
1.5	6	67	11.7	34,900	69,800	209,400

3.4.5.1 Finish. Rings shall be as specified in 3.2.1.3.

3.4.6 Type VII, swivels.

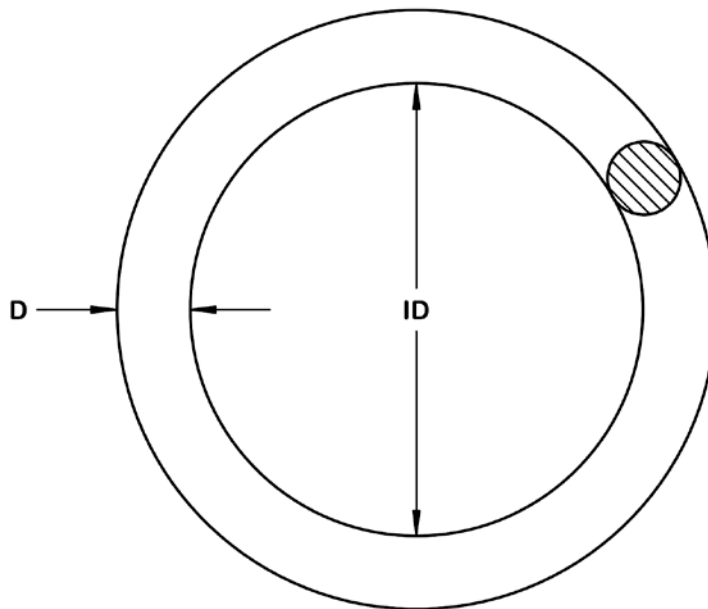
3.4.6.1 General. Type VII swivels, together with their pins, shall be forged from carbon steel as specified in B.2.2.7. Nuts shall be regular hexagonal.

3.4.6.1.1 Finish. The swivels and pins shall be as specified in 3.2.1.3.

3.4.6.1.2 Proof load. The swivels shall withstand the proof loads in the respective class tables (see table XVII, table XVIII or table XIX and 4.4.2.5.1).

3.4.6.1.3 Breaking load. The swivels shall withstand, without breaking, breaking loads shown in the respective class tables (see table XVII, table XVIII or table XIX and 4.4.2.5.1).

3.4.6.2 Type VII, class 1, chain swivels. The chain swivels shall be similar to figure 24 and shall be in accordance with the dimensions and physical requirements as shown in table XVII.

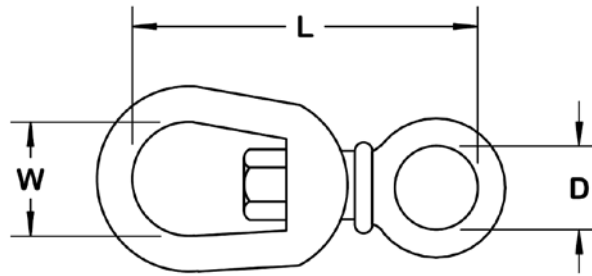

FIGURE 24. Type VII, class 1, chain swivel.

TABLE XVII. Type VII, class 1, chain swivels.

Trade size (nom) (inch)	PIN Size Number	Length (L) (min) (inch)	Width (W) (nom) (inches)	Eye dia. (D) (min)	Weight per 100 (approx) (pounds)	Working load limit (pounds)	Proof load (min) (pounds)	Breaking load (min) (pounds)
1/4	08	2.250	0.75	0.43	13	800	1,600	4,000
5/16	10	2.719	1.00	0.50	25	1,200	2,400	6,000
3/8	12	3.438	1.25	0.75	50	2,200	4,400	11,000
1/2	16	4.250	1.50	0.87	100	3,500	7,000	17,500
5/8	20	5.125	1.75	1.06	175	5,200	10,400	26,000
3/4	24	5.781	2.00	1.25	287	7,100	14,200	35,500

3.4.6.3 Class 2, eye and eye swivels. The eye and eye swivels shall be similar to figure 25, and shall be in accordance with the dimensions and physical requirements as shown in table XVIII.

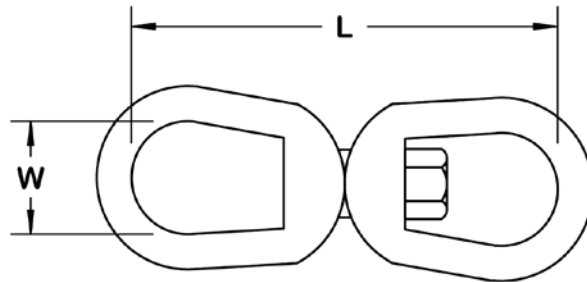

FIGURE 25. Type VII, class 2, eye and eye swivel.

TABLE XVIII. Type VII, class 2, eye and eye swivels.

Trade size (nom) (inch)	PIN Size Number	Length (L) (min) (inch)	Width (W) (nom) (inches)	Weight per 100 (approx) (pounds)	Working load limit (pounds)	Proof load (min) (pounds)	Breaking load (min) (pounds)
1/4	08	2.875	0.75	17.5	800	1,600	4,000
5/16	10	3.500	1.00	32.5	1,200	2,400	6,000
3/8	12	4.250	1.25	63	2,200	4,400	11,000
1/2	16	5.438	1.50	132	3,500	7,000	17,500
5/8	20	6.562	1.75	250	5,200	10,400	26,000
3/4	24	7.188	2.00	375	7,100	14,200	35,500
7/8	28	8.375	2.25	600	9,200	18,400	46,000
1	32	9.625	2.50	900	11,600	23,200	56,200
1-1/8	36	10.375	2.75	1,246	15,000	30,000	75,000
1-1/4	40	11.125	3.12	1,637	18,000	36,000	90,000
1-1/2	48	16.688	4.00	4,906	45,000	90,000	225,000

3.4.6.4 Class 3, jaw and eye swivels. The jaw and eye swivels shall be similar to figure 26, and shall be in accordance with the dimensions and physical requirements as shown in table XIX.

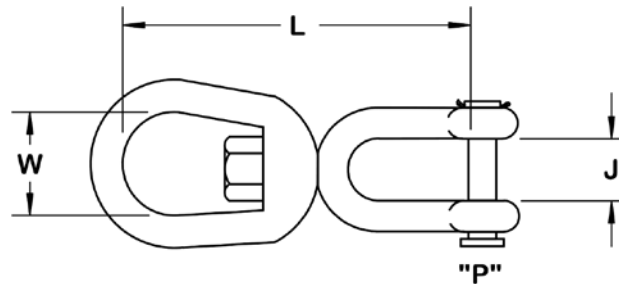

FIGURE 26. Type VII, class 3, jaw and eye swivel.

TABLE XIX. Type VII, class 3, jaw and eye swivels.

Trade size (nom) (inch)	PIN Size Number	Length (L) (min) (inch)	Width (W) (nom) (inch)	Jaw opening (J) (min) (inch)	Pin dia. (P) (min) (inch)	Weight per 100 (approx) (pounds)	Working load limit (pounds)	Proof load (min) (pounds)	Breaking load (min) (pounds)
1/4	08	2.438	0.75	0.46	0.25	21	800	1,600	4,000
5/16	10	2.812	1.00	0.50	0.31	34	1,200	2,400	6,000
3/8	12	3.500	1.25	0.62	0.37	62	2,200	4,400	11,000
1/2	16	4.500	1.50	0.75	0.50	125	3,500	7,000	17,500
5/8	20	5.312	1.75	0.93	0.62	235	5,200	10,400	26,000
3/4	24	6.062	2.00	1.12	0.75	350	7,100	14,200	35,500
7/8	28	7.000	2.25	1.18	0.87	575	9,200	18,400	46,000
1	32	8.250	2.50	1.75	1.12	950	11,600	23,200	56,200
1-1/8	36	8.938	2.75	1.75	1.12	1,100	15,000	30,000	75,000
1-1/4	40	9.438	3.12	2.06	1.37	1,575	18,000	36,000	90,000
1-1/2	48	14.250	4.00	2.87	2.25	5,475	45,000	90,000	225,000

3.4.7 Type IX, bead-chain fasteners (standard couplings with eyelets). The bead-chain fasteners shall be made of brass, corrosion resistant steel (CRES), or steel as specified in B.2.2.8, shall be similar to figure 27, and shall be in accordance with the dimensions and physical requirements as shown in table XX.

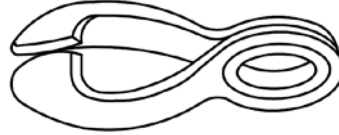

FIGURE 27. Type IX, bead-chain fastener.

TABLE XX. Type IX, bead-chain fasteners.

Trade no.	PIN Size Number	Size of chain used with (inch)	Length overall (approx) (inches)	Diameter of hole in eye (approx) (inch)	Weight per 100 couplings (approx) (pounds)
6 - AD	06	1/8	0.406	0.125	0.100
10 - A	10	3/16	0.500	0.125	0.187
10 - AD	11	3/16	0.562	0.188	0.250
13 - AN	13	1/4	0.688	0.188	0.312
20 - A	20	3/8	1.031	0.250	1.320

3.4.8 Type X, bead chain couplings. The bead-chain couplings shall be made of brass, CRES, or steel as specified in B.2.2.9, shall be similar to figure 28, and shall be in accordance with the dimensions and physical requirements as shown in table XXI.

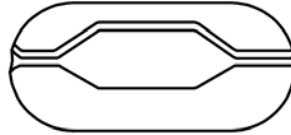

FIGURE 29. Type X, bead-chain coupling.

TABLE XXI. Type X, bead-chain couplings.

Trade no.	PIN Size Number	Size of chain used with (inch)	Length overall (approx) (inches)	Ring wire size (max) (inch)	Weight per 100 couplings (approx) (pounds)
3-L	03	3/32	0.375	-	0.0386
6-L	06	1/8	0.500	-	0.085
10-B	10	3/16	0.531	0.125	0.150
13-B	13	1/4	0.688	0.141	0.420

3.4.9 Type XI, bead-chain insulating couplings. The bead-chain insulating couplings shall be as shown on figure 30, and shall be in accordance with the dimensions and physical requirements shown in table XXII. The couplings shall have a hard fiber body fitted at each end with a brass, CRES or steel as specified in B.2.2.10 cap that shall have a hole and slot to receive bead chain. The couplings shall withstand dielectric strength tests (see 4.4.2.6).

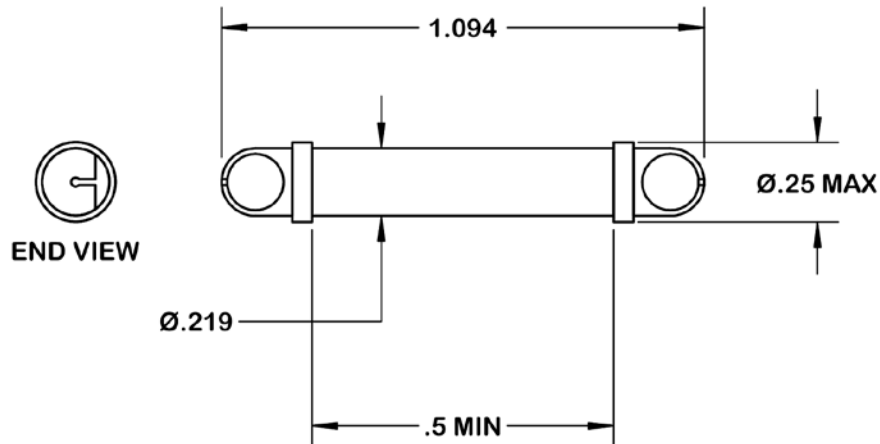
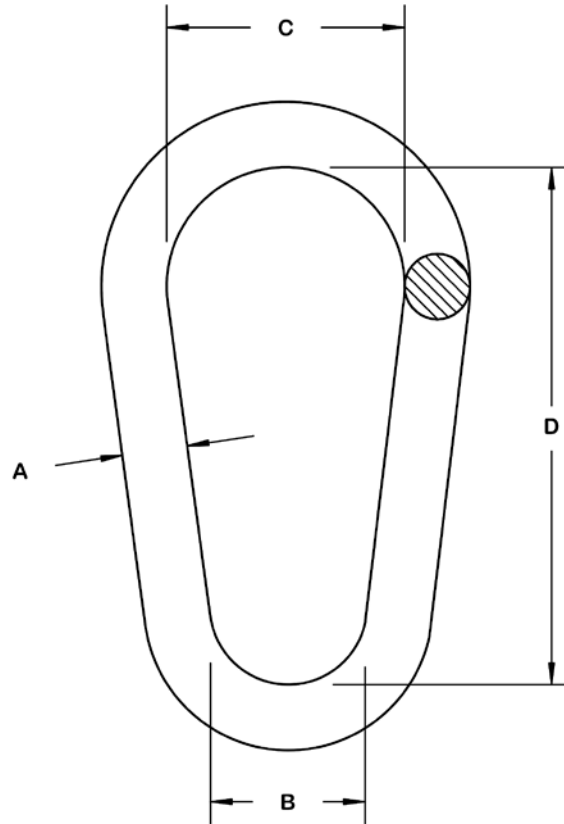

FIGURE 30. Type XI, bead-chain insulating coupling.

TABLE XXII. Type XI, bead-chain insulating coupling.

Size of chain used with (inch)	Length overall (approx) (inches)	Distance between metal ends (min) (inch)	Diameter of fiber rod (approx) (inch)	Breaking load (min) (pounds)
1/8	1.094	0.5	0.219	25

3.4.10 Type XIII, pear-shaped links. The pear-shaped links shall be forged or welded from alloy steel as specified in B.2.2.11. The links shall be heat treated, be similar to figure 31, and shall be in accordance with the sizes and weights as shown in table XXIII.

FIGURE 31. Type XIII, pear-shaped link.TABLE XXIII. Type XIII, pear-shaped links.

Nominal diameter (A) (inches)	PIN Size Number	Inside widths		Inside length (D) (approx) (inches)	Working load limit (pounds)	Proof load (min) (pounds)	Breaking load (min) (pounds)	Weight each (approx) (pounds)
		(B) (min) (inches)	(C) (min) (inches)					
1/2	16	1.00	2.00	3.00	3,600	7,200	14,400	0.8
5/8	20	1.25	2.50	3.75	6,250	12,500	25,000	1.4
3/4	24	1.50	2.75	4.50	9,000	18,000	36,000	2.1
7/8	28	1.75	3.00	5.25	11,400	22,800	45,600	2.8
1	32	2.00	3.50	6.00	16,000	32,000	64,000	4.6
1-1/4	40	2.50	4.37	7.75	25,650	51,300	102,600	9.0
1-3/8	42	2.75	5.00	8.25	30,750	61,500	123,000	11.5
1-1/2	48	3.00	5.25	10.50	34,900	69,800	139,600	15.3

3.4.10.1 Finish. The pear-shaped links shall be zinc coated in accordance with 3.2.1.4.

3.4.11 Type XIV, mechanical coupling links. The mechanical coupling links shall be forged from alloy steel as specified in B.2.2.12, shall be similar to figure 32, and shall be in accordance with the dimensions and physical requirements as shown in table XXIV.

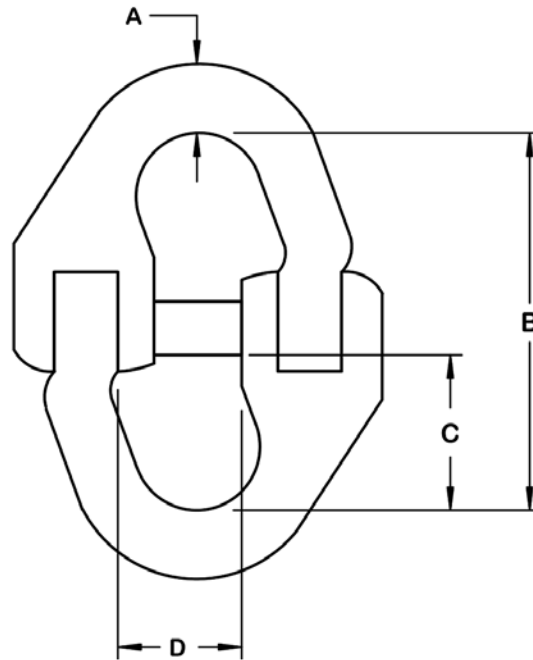

FIGURE 32. Type XIV, mechanical coupling link.

TABLE XXIV. Type XIV, mechanical coupling links.

Chain size (nom) (inch)	PIN Size Number	Dimensions (inches)								Weight each (approx) (pounds)
		(A)		(B)		(C)		(D)		
		min	max	min	max	min	max	min	max	
9/32	9S	0.300	0.440	1.810	2.300	0.625	0.810	0.540	0.810	0.24
5/16	05	0.360	0.490	2.130	2.810	0.830	0.890	0.680	1.000	0.35
3/8	06	0.437	0.590	2.325	3.060	0.828	1.180	0.812	1.090	0.50
1/2	08	0.580	0.780	3.160	3.860	1.200	1.480	1.000	1.312	1.3
5/8	10	0.710	0.910	3.800	4.595	1.437	1.740	1.250	1.593	2.3
3/4	12	0.875	1.180	4.500	5.438	1.770	2.090	1.520	1.875	4.0
7/8	14	1.000	1.250	4.800	5.970	2.031	2.450	1.750	2.281	4.3
1	16	1.116	1.380	5.750	6.500	2.187	2.750	2.000	2.625	8.4
1-1/4	20	1.400	1.700	6.750	8.280	2.812	3.610	2.500	3.125	15.5

TABLE XXIV. Type XIV, mechanical coupling links (continued).

Chain size (nom) (inch)	PIN Size Number	Working load limit (pounds)		Proof load (min) (pounds)		Breaking load (min) (pounds)	
		Grade A	Grade B	Grade A	Grade B	Grade A	Grade B
9/32	9S	3,500	4,300	7,000	8,600	14,000	17,200
5/16	05	4,500	5,700	9,000	11,400	18,000	22,800
3/8	06	7,100	8,800	14,200	17,600	28,400	35,200
1/2	08	12,000	15,000	24,000	30,000	48,000	60,000
5/8	10	18,100	22,600	36,200	45,200	72,400	90,400
3/4	12	28,300	35,300	56,600	70,600	113,200	141,200
7/8	14	34,200	42,700	68,400	85,400	136,800	170,800
1	16	47,700		95,400		190,400	
1-1/4	20	72,300		144,600		289,200	

3.4.12 Type XV, end links. The end links shall be manufactured from carbon or alloy steel conforming, as specified in B.2.2.13, and the limitation in chemical composition shall be as specified in table I; the links shall be heat treated, weldless, and similar to figure 33; and the links shall be in accordance with the dimensions and physical requirements as shown in table XXV.

FIGURE 33. Type XV, end link.

TABLE XXV. Type XV, end links.

<i>Trade size (nom) (inches)</i>	PIN Size Number	Inside length (nom) (inches)	Inside width (nom) (inches)	Weight each (approx) (pounds)	Working load limit (pounds)	Proof load (min) (pounds)	Breaking load (min) (pounds)
0.625	01	3.25	1.00	0.95	3,537	7,070	14,150
0.75	02	3.50	1.12	1.51	5,525	11,050	22,100
0.875	03	5.12	2.00	2.75	7,950	15,900	31,800
1	04	4.00	1.50	3.95	23,750	50,000	95,000

3.4.12.1 Finish. Links shall be zinc coated as specified in 3.2.1.4.

3.4.13 Type XVI, chain master links. The chain master links shall meet the requirements of ASTM A952/A952M for the sizes and grades listed in table XXVI.

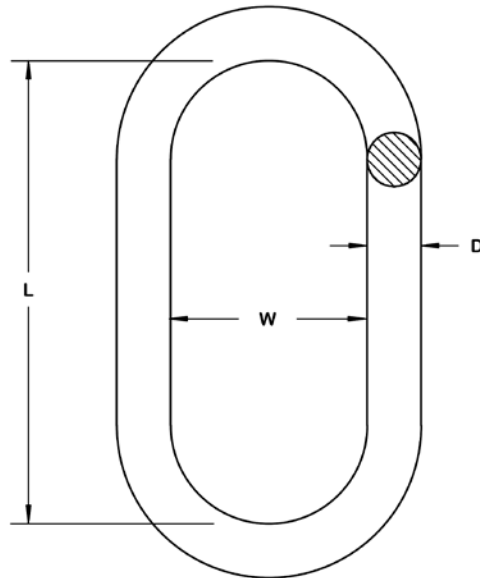
TABLE XXVI. Type XVI, chain master links.

Nominal size	Grade 80 PIN (see note)	Grade 100 PIN (see note)
5/16	105X	205X
3/8	106X	206X
1/2	108X	208X
5/8	110X	210X
3/4	112X	212X
7/8	114X	214X
1	116X	216X
1-1/4	120X	220X

Note: PIN is: first digit is grade, second and third are size in 16ths, fourth is number of legs (1-4)

3.5 Workmanship. The chain and attachments shall be free from injurious imperfections and defects that may impair appearance or serviceability. Chain and attachments shall be free from fins, cracks, flaws, or seams. The screw threads shall be true to form, clean cut, and free from injurious defects.

4. QUALITY ASSURANCE PROVISIONS

4.1 Responsibility for inspection. Unless otherwise specified in the contract, the contractor is responsible for the performance of all inspection requirements as specified herein. Except as otherwise specified in the contract, the contractor may use his own or any other facilities suitable for the performance of the inspection requirements specified herein, unless disapproved by the government. The government reserves the right to perform any of the inspections set forth in the specification where such inspections are deemed necessary to assure that supplies and services conform to prescribed requirements.

4.1.1 Responsibility for compliance. All items shall meet all requirements of sections 3 and 5. The inspections set forth in this specification shall become a part of the contractor's overall inspection system or quality program. The absence of any inspection requirements in the specification shall not relieve the contractor of the responsibility of ensuring that all products or supplies submitted to the Government for acceptance comply with all requirements of the contract. Sampling inspection, as part of the manufacturing operations, is an acceptable practice to ascertain conformance to requirements, however, this does not authorize submission of known defective material, either indicated or actual, nor does it commit the Government to accept defective material.

4.2 Quality conformance inspection. Conformance inspection shall consist of the examinations and tests as specified in 4.3 and 4.4.

4.2.1 Lot.

4.2.1.1 Type I, chain. For the purpose of inspection, a lot shall be in accordance with ASTM A391/A391M, ASTM A973/A973M, ASTM A413/A413M, and ASTM A467/A467M.

4.2.1.2 Type II, chain. For the purpose of inspection, a lot shall be in accordance with ASTM A466/A466M.

4.2.1.3 Attachments. For the purpose of inspection, a lot shall consist of not more than 10,000 attachments made from the same material, of the same type and class, offered for delivery at one time.

4.2.2 Sampling procedures.

4.2.2.1 Chain.

4.2.2.1.1 Visual and dimensional inspection. A portion of each lot of chain shall be selected for visual and dimensional inspection. If lots comprise more than one length of chain, the sample links shall be selected equally from each lot.

4.2.2.1.2 Types I and II. A random sample of chain not less than two feet long shall be selected from each lot for inspection. Every link in the sample shall be visually examined for conformance to the requirements of this specification.

4.2.2.1.3 Breaking test, weldless. A specimen not less than one foot long, from the finished chain, shall be selected from each lot to undergo breaking test specified in 4.4.1.1.

4.2.2.1.4 Breaking and elongation test, welded. A specimen in accordance with ASTM A391/A391M, ASTM A413/A413M, ASTM A467/A467M, or ASTM A973/A973M shall be selected from each lot to undergo breaking and elongation tests specified in 4.4.1.1 and 4.4.1.2.

4.2.2.2 Attachments.

4.2.2.2.1 Accept at zero sampling plans. Except as noted below or in the contract (see 6.2), sampling shall be to an “accept at zero” (c=0) sampling plan such as MIL-DTL-1916 at verification level IV or ASQ H1331 at AQL of 1.0.

4.2.2.2.2 Sampling for inspection and proof load. For all attachments except type II connecting links, type III lap links and type XI insulated couplings, a random sample of attachments for visual inspection and proof load shall be selected from each lot in accordance with 4.2.2.2.1.

4.2.2.2.3 Sampling for breaking and ductility tests. For all attachments except type II connecting links, type III lap links and type XI insulated couplings, a random sample of attachments shall be selected in accordance with table XXVII for the breaking and ductility tests specified in 4.4.2.

TABLE XXVII. Sampling for destructive testing of attachments.

Number of attachments per lot	Number to be selected for breaking load and ductility tests
1 to 8	1 ⁽¹⁾
9 to 50	2
51 to 500	3
501 to 10,000	5

(1) Type II interchangeability inspection requires 2 links

4.2.2.2.4 Type II and type III links. For visual inspection of type II connecting links and type III lap links, a random sample of attachments shall be selected from each lot in accordance with 4.2.2.2.1. For proof and break testing, a sample of attachments shall be randomly selected in accordance with table XXVII. For type II links, 2 link halves are required for each test link.

4.2.2.2.5 Type XI, bead chain insulating couplings. For visual inspection of type XI couplings, a random sample of attachments shall be selected from each lot in accordance with 4.2.2.2.1. For dielectric strength testing as specified in 4.4.2.6, a random sample shall be selected from each lot as shown in table XXVIII.

TABLE XXVIII. Sampling procedure for type XI, bead chain insulating couplings.

Number of couplings per lot	Number of samples to be selected for dielectric strength test
1 to 50	2
51 to 1,000	4
1,001 to 10,000	10

4.2.2.3 Chemical analysis. Steel chemistry of material for chain and attachments shall be determined from the certified mill data sheet or by analysis of either bars or from finished chain or attachments.

4.3 Examination.

4.3.1 Chain. Each sample of chain selected as specified in 4.2.2.1 shall be examined to determine conformance to this specification regarding dimensions, finish, quality of welds, and other requirements. Chain shall be measured to the inside of the end links after the chain has been proof tested.

4.3.2 Attachments. A random sample of attachments as specified in 4.2.2.2 shall be examined to determine conformance to this specification regarding dimensions, finish, quality of welds, and other requirements. If attachments are to be zinc coated, surface inspection shall be made before and after coating. Proof and breaking tests shall be made after zinc coating.

4.3.3 Rejections.

4.3.3.1 Chain. If the inspection sample fails to meet the requirements as specified in 4.3.1, the lot shall be rejected.

4.3.3.2 Attachments. Sample attachments failing to conform to the requirements specified in 4.3.2 shall be rejected. If any defects are noted in the original sample attachments, additional attachments shall be randomly selected as specified in the original sampling plan, and if any defects are noted, the entire lot shall be rejected.

4.4 Test methods.

4.4.1 Chain.

4.4.1.1 Breaking test. Breaking tests shall be performed in accordance with ASTM A391/A391M, ASTM A413/A413M, ASTM A466/A466M, ASTM A467/A467M, or ASTM A973/A973M, as appropriate.

4.4.1.2 Elongation test (type I only). Elongation tests (type I only) shall be performed in accordance with ASTM A391/A391M, ASTM A413/A413M, ASTM A466/A466M, ASTM A467/A467M, or ASTM A973/A973M, as appropriate.

4.4.1.3 Proof test. Proof tests shall be performed in accordance with ASTM A391/A391M, ASTM A413/A413M, ASTM A466/A466M, or ASTM A467/A467M, as appropriate.

4.4.2 Attachments.

4.4.2.1 Type II, connecting links.

4.4.2.1.1 Interchangeability check. The links selected for proof and break load testing shall be visually inspected to ensure that all links are interchangeable without applying force. The two halves shall fit concentrically to each other and shall mate (face flush fit) to each other maintaining rivet-pin to hole alignment.

4.4.2.1.2 Rivet size. The rivets shall be of sufficient diameter and length to completely fill countersunk holes when peened. Rivet size shall be checked on samples assembled for proof and break testing.

4.4.2.1.3 Proof and breaking tests. The breaking and proof tests shall be conducted in accordance with ASTM A952/A952M procedures for single leg assemblies, using the loads specified in table VI. If any sample link fails the proof or breaking test, the lot shall be rejected.

4.4.2.2 Type IV, shackles.

4.4.2.2.1 Proof test. Samples shall be subjected to proof loads shown in table VIII either singly or in series. The diameter of the attachments used in proofing shall be not greater than the pin diameter of the shackle being tested and the application of the proof load shall be at the center of the pin. After releasing the proof load, each shackle shall be examined and disassembled as specified in 3.4.3.1.2.

4.4.2.2.2 Breaking load and ductility tests. After proof testing, the required number of samples shall be subjected to the breaking load test to determine compliance with table VIII. The diameter of the attachment used in the breaking test shall be not greater than the pin diameter of the shackle being tested; the application of the load shall be at the center of the pin. After breaking, the sample shall be inspected and measured to determine conformance with 3.4.3.1.5.

4.4.2.2.3 Rejections. If any shackle fails to pass the proof load, breaking load, or ductility test, all shackles in the lot shall be rejected.

4.4.2.3 Type V, hooks.

4.4.2.3.1 Proof test. Samples shall be subjected to the applicable proof loads provided in this specification. Hooks shall withstand the proof test with no more than 1% permanent opening of the hook at the throat.

4.4.2.3.2 Breaking load and ductility tests. Samples subjected to the breaking load strength test shall exhibit permanent deformation in the throat opening after failure.

4.4.2.3.3 Rejections. If any hook fails to pass the proof load, break load, or ductility tests, the lot shall be rejected.

4.4.2.4 Type VI, rings.

4.4.2.4.1 Proof test. Samples selected in accordance with 4.2.2.2.1 shall be subjected to the proof and breaking loads shown in table XVI. The samples shall withstand the proof load without loss of integrity or detrimental dimensional change. A dimensional change of greater than 1% shall be deemed detrimental.

4.4.2.4.2 Breaking load test. Samples subjected to the breaking load test shall withstand the breaking loads shown in table XVI.

4.4.2.4.3 Rejections. If any ring fails to pass the proof load or breaking load tests, all rings of the lot shall be rejected.

4.4.2.5 Type VII, swivels.

4.4.2.5.1 Proof load and breaking load test. Samples shall be subjected to the proof loads and breaking loads shown in tables XVII, XVIII, or XIX as applicable, either singly or in series. The swivels shall withstand the proof loads without developing surface rupture or defects that would interfere with serviceability.

4.4.2.5.2 Rejections. If any swivel fails to pass the proof or breaking load tests, all swivels in the lot shall be rejected.

4.4.2.6 Type XI, bead-chain insulating coupling dielectric strength test. Samples selected in accordance with table XXII shall be tested for dielectric strength. One half of the samples shall be dried in a desiccator for 24 hours, removed, and immediately subjected to 10,000 volts. The remaining couplings shall be stored for 48 hours in an atmosphere of 35 °C (95 °F), 90 percent relative humidity, and immediately subjected to 4,000 volts. A tolerance of plus 1 hour and plus or minus 2 percent relative humidity will be permitted. The difference in potential for both samples shall be maintained for 1 minute.

4.4.2.7 Type XIII, pear-shaped links.

4.4.2.7.1 Proof test. Samples selected as specified in 4.2.2.2.1 shall be subjected to the proof loads as shown in table XXIII. The samples shall withstand the proof load without loss of integrity or detrimental dimensional change. A dimensional change of greater than 1% shall be deemed detrimental.

4.4.2.7.2 Breaking load test. After proof testing, samples selected as specified in 4.2.2.2.1 shall be subjected to the breaking loads as shown in table XXIII.

4.4.2.7.3 Rejections. If any link fails to pass the proof load or breaking load tests, the lot shall be rejected.

4.4.2.8 Type XIV mechanical coupling links.

4.4.2.8.1 Proof test. Samples selected as specified in 4.2.2.2.1 shall be subjected to the proof loads as shown in table XXIV. The mechanical coupling links shall be visually examined following proof load testing.

4.4.2.8.2 Breaking load test. After proof testing, samples selected as specified in 4.2.2.2.1 shall withstand the breaking loads as shown in table XXIV.

4.4.2.8.3 Rejections. There shall be no evidence of damage or deformation following proof load testing. If any mechanical coupling links fails to pass the proof load or breaking load tests, the lot shall be rejected.

4.4.2.9 Type XV end links.

4.4.2.9.1 Proof test. Samples selected as specified in 4.2.2.2.1 shall be subjected to the proof loads as shown in table XXV. The samples shall withstand the proof load without loss of integrity or detrimental dimensional change. A dimensional change of greater than 1% shall be deemed detrimental.

4.4.2.9.2 Breaking load test. After proof testing, samples selected as specified in 4.2.2.2.1 shall be subjected to the breaking loads as shown in table XXV.

4.4.2.9.3 Rejections. If any sample link fails the proof or breaking test, the lot shall be rejected.

4.4.2.10 Type XVI chain master links.

4.4.2.10.1 Proof test. Samples shall be subjected to the applicable proof loads provided in ASTM A952/A952M. The chain master links shall withstand the proof test.

4.4.2.10.2 Breaking load and Ductility tests. Samples subjected to the breaking load strength test shall exhibit permanent deformation of a dimension by more than 15 percent from its original condition.

4.4.2.10.3 Rejections. If any chain master link fails to pass the proof load, break load, or ductility tests, the lot shall be rejected.

4.5 Inspection of packaging. Sample packs and the inspection of presentation, packing and marking for shipment, stowage, and storage shall be in accordance with the requirements of section 5.

5. PACKAGING

(The packaging requirements specified herein apply only for direct Government acquisition.)

5.1 Preservation. Preservation shall be level A or commercial, as specified (see 6.2).

5.1.1 Level A. Chain and attachments shall be preserved in accordance with method 30 (or greater) of MIL-STD-2073-1.

5.1.1.1 Chain weighing less than 35 pounds per 100 feet and attachments weighing less than 5 pounds each shall be packed in weather-resistant fiberboard boxes. The gross weight of the boxes shall not exceed the limitations of the applicable box specification.

5.1.1.2 Chain weighing in excess of 35 pounds per 100 feet and attachments weighing in excess of 5 pounds each shall be bulk-packed in containers as specified in 5.2.

5.1.2 Commercial. Chain and attachments shall be preserved in accordance with ASTM D3951.

5.2 Packing. Packing shall be method 30 (or greater) of MIL-STD-2073-1, or commercial as specified (see 6.2).

5.2.1 General requirements. Selected containers (see 5.2.2) shall be of minimum weight and cube consistent with the protection required, shall be of uniform size, and shall contain identical quantities, as appropriate.

5.2.2 Chains and attachments. Chain and attachments preserved as specified (see 5.1) shall be packed in exterior shipping containers in accordance with MIL-STD-2073-1, method 30, for the level of packing specified (see 5.2). Unless otherwise specified (see 6.2), container selection including container options shall be the contractor's option.

5.2.2.1 Closures, gross weight, and waterproofing.

5.2.2.1.1 Closure. Container closure, reinforcing, or banding shall be in accordance with the applicable container specification, except that weather-resistant fiberboard boxes shall be closed and reinforced with non-metallic or tape banding; and domestic non-weather-resistant fiberboard boxes shall be closed using pressure sensitive tape.

5.2.2.1.2 Weight. Wood, plywood, and wood-cleated type containers exceeding 200 pounds gross weight shall be modified by the addition of skids in accordance with MIL-STD-2073-1, or the applicable container specification.

5.2.2.1.2.1 Chains exceeding 1000 pounds net weight. Unless otherwise specified (see 6.2(o)), single chain lengths exceeding 1000 pounds net weight shall be boxed, packed in drums, or shipped loose in accordance with the requirements of the applicable carrier.

5.2.2.1.3 Waterproofing. Unless otherwise specified (see 6.2), shipping containers shall be provided with case liners, linings, wraps, or shrouds.

5.2.3 Commercial. Chain and attachments preserved as specified (see 5.1) shall be packed for shipment in accordance with ASTM D3951 and herein.

5.2.3.1 Container modification. Shipping containers exceeding 200 pounds gross weight shall be provided with a minimum of two, 3 x 4-inch nominal wood skids laid flat; or a skid or sill-type base which will support the material and facilitate handling by mechanical handling equipment during shipment, stowage, and storage.

5.3 Palletized unit loads. When specified (see 6.2), containers shall be palletized in accordance with MIL-STD-2073-1.

5.4 Marking.

5.4.1 Chains and attachments. In addition to any special marking required (see 6.2), interior (unit) packs, shipping containers, and palletized unit loads shall be marked in accordance with MIL-STD-2073-1 for military agencies and FED-STD-123 for civil agencies and shall include barcodes and applicable packaging acquisition options herein as specified herein (see 6.2).

6. NOTES

INFORMATION FOR GUIDANCE ONLY. (This section contains information of a general or explanatory nature that is helpful, but is not mandatory.)

6.1 Intended use.

6.1.1 Type I, chain, welded steel. Type I is steel chain intended for general service. Type I, class 1, is a special analysis alloy steel recommended for overhead lifting and wherever long life and extremely high tensile strengths are desired.

6.1.2 Type II, chain, weldless. Type II, class 11, mechanical communication chain is intended for use in pulleys used on a line of signal transmission of mechanical telegraphs, i.e. ship's bridge to engine room communication.

6.1.3 Type IV, shackles.

6.1.3.1 Class 1 shackles. Class 1 pin and cotter pin shackles are intended for general use except overhead lifting.

6.1.3.2 Class 2 and 3 shackles. Class 2 screw-in pin shackles and 3 bolt and nut shackles are intended for general use including overhead lifting.

6.1.4 Type V, hooks.

6.1.4.1 Style 1 and 3 hooks. Style 1 slip hooks and style 3 sling hooks are intended to connect chain to a load.

6.1.4.2 Style 2 hooks. Style 2 grab hooks are intended to connect chain to chain at a specific link.

6.1.4.3 Style 4 hooks. Style 4 hoist hooks are intended to connect wire rope to a load.

6.1.5 Type XV, end links. End links in accordance with this specification are intended for use with fueling at sea rigging.

6.2 Acquisition requirements. Acquisition documents should specify the following as applicable. The PIN designation (see Appendix A) may be used in place of some requirements.

- a. Title, number, and date of this specification.
- b. Type, class, and style of chain; and type, grade, and class of attachments required (see 1.2.1 and 1.2.2).
- c. Material required for type II, classes 1, 2, 3, 4, 6, 7, 8, 9, and 10 chains (see B.2.1.3).
- d. Material required for type II, class 5 bead chain (see B2.1.4), and type IX, X, and XI fasteners/couplings (see B.2.2.8, B2.2.9 or B.2.2.10).
- e. Finish required, if other than that specified (see 3.2.1).
- f. Finish specific to type I chain (see 3.2.1.1).
- g. Finish specific to type II chain (see 3.2.1.2).
- h. Finish specific to attachments (see 3.2.1.3).
- i. Fine threads for shackles, if required (see 3.4.3.1.1).
- j. Form and dimensions of shackles (3.4.3.2).
- k. AQL (see 4.2.2.2.1).
- l. Size of chain or attachments required (see applicable tables).
- m. Whether purchasing type I or type II chain by the foot.
- n. Level of preservation, packaging, and packing required (see 5.1 and 5.2).

- o. Special shipping method for single chain lengths exceeding 1000 pounds net weight if required (see 5.2.2.1.2.1).
- p. Container selection, if not contractor's option (see 5.2.2).
- q. Waterproofing packaging requirements, other than specified (5.2.2.1.3).
- r. When palletization is required (see 5.3).
- s. Special marking, if required (see 5.4.1).

6.3 Definitions.

6.3.1 Breaking load. Minimum force in pounds at which the chain, during manufacture, has been found by testing to break when a constantly increasing force is applied in direct tension. This test is a manufacturer's attribute acceptance test and shall not be used as criteria for service or design purposes.

6.3.2 Proof load. Quality control tensile test applied to chain for the purpose of verifying weld and material quality. It is the minimum force in pounds which the chain has withstood at the time it left the producer, under a test in which a constantly increasing force has been applied in direct tension to a straight length of chain. Proof loads are a manufacturing integrity test and shall not be used as criteria for service or design purposes.

6.3.3 Working load limit. Maximum combined static and dynamic load in pounds that shall be applied in direct tension to an undamaged straight length of chain.

6.4 Subject term (key word) listing.

Alloy chain	Anchor shackle
Appendage	Barrel hook
Breaking load	Chain master links
Double jack	Ductility
End link	Eye swivel
Grab hook	Ground tackle
Hook	Insulating coupling
Pear-shaped	Proof load
Register chain	Plumber's chain
Sash chain	Shackle
Single jack	Sling hook
Slip hook	Swivel
Transport chain	

6.5 Changes from previous issue. Margin notations are not used in this revision to identify changes with respect to the previous issue due to the extensive changes.

PART IDENTIFICATION NUMBER (PIN) SYSTEM

A.1 SCOPE

A.1.1 Scope. This appendix provides the details of the PIN system for RR-C-271.

A.1.2 Reason for appendix. There has previously been no PIN system for RR-C-271. Due to the varied requirements of the items defined in the specification, a single PIN configuration was found to be ineffective so a separate configuration was developed for each item type.

A.2 ELEMENTS OF PIN SYSTEM

A.2.1 Specification number. The designation F271 designates that the PIN is related to Federal Specification RR-C-271.

A.2.2 Type designation. The item type as given in 1.2.1 and 1.2.2 is designated by a slash number following the specification number. The slash numbers are given in 1.2.1 and 1.2.2.

A.2.3 Additional PIN elements. PINs may have no additional elements beyond F271/# or may have 1 or more of the following elements. The letter in parenthesis at the end of the element title is the symbol used in the PIN configuration descriptions of A.3. Relevant elements and the allowable ranges for each item type is defined in A.3

A.2.3.1 Class. The class defines physically different items under a given type.

A.2.3.2 Style. The style defines a variation of a class. The style element is only applicable to type 1, class 5 chain and is used to designate a variation in the class.

A.2.3.3 Finish. Finish defines the type of finish and requirements as specified in 3.2.1. Finishes are:

- a. S – self-colored finish
- b. B – bright finish
- c. Z – zinc-coated
- d. P - painted

A.2.3.4 Size. The size designation varies between items and may be a nominal size or a trade number. Some item types may have both nominal size and trade number designations.

A.2.3.5 Latch. The latch element is only applicable to type V hooks. Allowable designations are:

- a. L – a latch is installed on the hook or is included in the package
- b. N – a latch is not included with the item
- c. X – a latch is not applicable to the hook class

RR-C-271G
APPENDIX A

A.2.3.6 Material. The material element is used when only material families are specified without other restrictions. Materials may include:

- a. Aluminum – A
- b. Brass – B
- c. Bronze – R (not Z as this could be confused with the zinc finish designation)
- d. Corrosion resistant steel (CRES) – C
- e. Steel - S

A.2.3.7 Grade. The grade element defines strength variations within a class for chains or a type for chain attachments.

A.2.3.8 Thread. The thread element is only applicable to type IVA and IVB shackles that are of a fine thread design.

- a. No code – normal coarse thread
- b. F – fine thread design

A.2.3.9 Chain length exclusion. The length of the chain is specifically not included in the PIN due to the ease of cutting chain in the field and the near infinite variation in available lengths.

A.3 CONFIGURATION OF PIN

A.3.1 PIN configuration by item type. The PIN configuration for each type item is given below. The relevant elements for each type are given in order along with the allowed variables. The type slash numbers are given in 1.2.1 and 1.2.2.

A.3.1.1 F271-C1 – type I welded chain.

Class –	1, 2, 3, 4 or 5
Grade or Style –	Grade for Class=1 only A for grade 80 B for grade 100 Style for Class=5 only C for style 1, long-link D for style 2, short-link X all others
Finish –	S, B, Z or P except that class 1 is B or P only
Size –	class 1 through class 4, 2 digit nominal size in 1/16 inches per ASTM A391/A391M except class 1 also has 7S = 7/32 and 9S = 9/32. class 5, size designation per 3.3.1.5.1 or 3.3.1.6.1

RR-C-271G
APPENDIX A

Examples: F271-C1-1AB9S – alloy chain, grade 80, bright finished, 9/32 inch
F271-C1-3XZ32 – transport chain, zinc coated, 2 inch
F271-C1-5CS40 – twist-link chain, long-link pattern (coil),
self-colored finished, trade size 4/0 (5.5 mm) (not same as trade size 4
(3.0 mm))

A.3.1.2 F271-C2 – type II weldless chain.

Class – 1, 2, 3, 4, 5, 6, 7, 8, 9, 10 or 11
Material – A – aluminum, class 6 only
B – brass, all classes
R – bronze. class 1 - class 4, class 7 – class 10
C – CRES, class 5 only
S – steel, class 1 – class 10
Finish – S or Z
Size – PIN size designation per the following paragraphs or tables:
class 1 – 3.3.2.1.1
class 2 – 3.3.2.2.1
class 3 – 3.3.2.3.1
class 4 – table II
class 5 – table III
class 6 – 3.3.2.6.1
class 7 – 3.3.2.7.1
class 8 – 3.3.2.8.1
class 9 – table IV
class 10 – 3.3.2.10.1
X for not applicable, class 11 – only 1 size

Examples: F271-C2-4SZ02 – flat-link chain, steel, zinc coated, trade size 2-0
F271-C2-7RS16 – single jack chain, bronze, self-colored, trade size 16
F271-C2-11BSX – communication chain, brass, self-colored, size
not applicable

A.3.1.3 F271-A2 – connecting link (type II attachment).

Finish – S, P or Z
Size – size per table VI (1/16 inches)

Example: F271-A2-P20 – connecting link, painted, 1-1/4 inch size

RR-C-271G
APPENDIX A

A.3.1.3.1 Supersession of cancelled MS87008 PIN. The PIN for the cancelled MS87008 links are as given in table A.1.

Table A.1 – PIN supersession.

Size	MS87008 PIN	F271-A2 PIN	Size	MS87008 PIN	F271-A2 PIN
3/16	MS87008-21	F271-A2-Z03	1/4	MS87008-1	F271-A2-Z04
5/16	MS87008-2	F271-A2-Z05	3/8	MS87008-3	F271-A2-Z06
7/16	MS87008-4	F271-A2-Z07	1/2	MS87008-5	F271-A2-Z08
9/16	MS87008-6	F271-A2-Z09	5/8	MS87008-7	F271-A2-Z10
3/4	MS87008-9	F271-A2-Z12	7/8	MS87008-10	F271-A2-Z14
7/8	MS87008-10	F271-A2-Z14	1	MS87008-11	F271-A2-Z16
1-1/8	MS87008-12	F271-A2-Z18	1-1/4	MS87008-22	F271-A2-Z20

A.3.1.4 F271-A3 – lap link (type III attachment).

Finish – S, P or Z
Size – size per table VII

Example: F271-A3-Z05 – lap link, zinc coated, 2 inch inside length with .25 inch stock diameter

A.3.1.5 F271-A41 – anchor shackle (type IVA attachment).

Grade – A or B
Class – 1, 2 or 3
Finish – S, P or Z
Size – size per table VIII (1/16 inches)
Thread – no code or F

Examples: F271-A41-B1P12 – anchor shackle, high strength, round pin and cotter, painted, 3/4 inch size
F271-A41-A3Z20F – anchor shackle, regular strength, bolt/nut/cotter, zinc coated, 1-1/4 inch size, fine thread

A.3.1.6 F271-A42 – chain shackle (type IVB attachment).

Grade – A or B
Class – 1, 2 or 3
Finish – S, P or Z
Size – size per table VIII (1/16 inches)
Thread – no code or F

Examples: F271-A42-B3Z40 – chain shackle, high strength, bolt/nut/cotter, Zinc coated, 2-1/2 inch size
F271-A42-A2P04F – chain shackle, regular strength, screw pin, painted 1/4 inch size, fine thread

RR-C-271G
APPENDIX A

A.3.1.7 F271-A5 – hooks (type V attachment).

For class 1 through 5 hooks

Class – 1, 2, 3, 4 or 5
Grade – A or B for class 1 only
X for all other classes
Style – 2 digit style per 1.2.2
Latch – L, N or X
Finish – S, P or Z
Size – classes 1 through 4, nominal chain size in 1/16s inch (2 digits)
class 5, PIN size designation per table XV

For class 6 hooks

Class – 6 only
Finish – S, P or Z

Examples: F271-A5-1A2CXP10 – Alloy hook, grade A, clevis grab style, latch not applicable, painted, 5/8 inch size
F271-A5-5X4ELS015 – Hoist hook, grade not applicable, eye hoist style latch installed or included, self-colored, 1.5 ton capacity
F271-A5-6Z – eye barrel hook, zinc coated

A.3.1.8 F271-A6 – rings (type VI attachment).

Finish – S, P or Z
Size – by size in table XVI

Example: F271-A6-S66 – ring, self-colored, size 66 (6 inch ID, 1-3/8 stock dia.)

A.3.1.9 F271-A7 – swivels (type VII attachment).

Class – 1, 2 or 3
Finish – S, P or Z (no hot dip zinc)
Size – size per tables (1/32 inches)
class 1 – table XVII
class 2 – table XVIII
class 3 – table XIX

Example: F271-A7-2P16 – eye and eye swivel, painted, 1/2 inch

RR-C-271G
APPENDIX A

A.3.1.10 F271-A9 – bead chain fasteners (type IX attachment).

Material – B, C or S
Finish – S, P or Z
Size – trade number in table XX

Example: F271-A9-CS11 – bead chain fastener, CRES, self-colored,
trade size 10-AD

A.3.1.11 F271-A10 – bead chain couplings (type X attachment).

Material – B, C or S
Finish – S, P or Z
Size – trade number in table XXI

Example: F271-A10-SZ10 – bead chain coupling, steel, zinc coated,
trade size 10-B

A.3.1.12 F271-A11 – bead chain insulating couplings (type XI attachment).

There is only one item in type XI.

Example: F271-A11

A.3.1.13 F271-A13 – pear-shaped links (type XIII attachment).

The only material for type XIII links is zinc coated steel
Size – PIN size designation per table XXIII

Example – F271-A13-28 – pear shape link, 7/8 inch size

A.3.1.14 F271-A14 – mechanical coupling links (type XIV attachment).

Finish – S, P or Z
Grade – A for grade 80
B for grade 100
Size – size per table XXIV

Example: F271-A14-PA9S – mechanical coupling link, painted, grade 80, 9/32 size

A.3.1.15 F271-A15 – end links (type XV attachments).

Size – size per table XXV

Example F271-A15-02 – end link, 3/4 inch trade size

RR-C-271G
APPENDIX A

A.3.1.16 F271-A16 – chain master links (type XVI attachments).

Finish – S, P or Z
Size – PIN code from table XXVI

Example: F271-A16-P2104 – chain master link, painted, grade 100, 5/8 nominal size, for 4 legs.

RR-C-271G
APPENDIX B
MATERIAL REQUIREMENTS

B.1 SCOPE

B.1.1 Scope. This appendix provides the material requirements for the chains and chain attachments of this specification. Section B.2 gives the items with the allowable materials.

B.2 Allowable material by item.

B.2.1 Chain materials.

B.2.1.1 Type I, class 1 chain. Unless otherwise specified, type I, class 1 chain shall be manufactured from alloy steel conforming to ASTM A322, ASTM A304 or ASTM A510/A510M.

B.2.1.2 Type I, class 2, 3, 4 and 5 chain. Unless otherwise specified, type I, class 2, 3, 4 and 5 chain shall be manufactured from carbon steel conforming to ASTM A510/A510M, ASTM A576, ASTM A920/A920M, ASTM A909/A909M, or ASTM A921/A921M.

B.2.1.3 Type II, class 1, 2, 3, 4, 7, 8, 9 and 10 chain. Type II, class 1, 2, 3, 4, 7, 8, 9 and 10 chain shall be manufactured from one of these listed materials as specified in the procurement document.

- a. Steel composition at manufacturer's option
- b. Brass composition at manufacturer's option
- c. Bronze composition at manufacturer's option

B.2.1.4 Type II, class 5 chain. Type II, class 5 chain shall be manufactured from one of these listed materials as specified in the procurement document.

- a. Steel composition at manufacturer's option
- b. CRES composition at manufacturer's option
- c. Brass composition at manufacturer's option

B.2.1.5 Type II, class 6 chain. Type II, class 6 chain shall be manufactured from one of these listed materials as specified in the procurement document.

- a. Steel composition at manufacturer's option
- b. Brass composition at manufacturer's option
- c. Aluminum composition at manufacturer's option

B.2.1.6 Type II, class 11 chain. Unless otherwise specified, type II, class 11 chain shall be manufactured from Brass with composition at manufacturer's option.

RR-C-271G
APPENDIX B

B.2.2 Attachment materials.

B.2.2.1 Type II connecting links. Unless otherwise specified, type II connecting links shall be manufactured from carbon steel conforming to ASTM A510/A510M, ASTM A576, ASTM A920/A920M, ASTM A909/A909M, or ASTM A921/A921M.

B.2.2.2 Type III lap links. Unless otherwise specified, type III lap links shall be manufactured from carbon steel conforming to ASTM A510/A510M, ASTM A576, ASTM A920/A920M, ASTM A909/A909M, or ASTM A921/A921M.

B.2.2.3 Type IVA and type IVB, grade A shackles. Unless otherwise specified, type IVA and type IVB, grade A shackles shall be made of carbon steel conforming to ASTM A576, ASTM A920/A920M, ASTM A909/A909M, or ASTM A921/A921M.

B.2.2.3.1 Pins and bolts for grade A shackle. Unless otherwise specified, pins and bolts for grade A shackles shall be made of carbon steel conforming to ASTM A576, ASTM A920/A920M, ASTM A909/A909M, or ASTM A921/A921M or alloy steel conforming to ASTM A322 at the manufacturers option.

B.2.2.4 Type IVA and type IVB, grade B shackles. Unless otherwise specified, type IVA and type IVB, grade B shackles, pins and bolts shall be manufactured from alloy steel conforming to ASTM A322.

B.2.2.5 Type V hooks.

B.2.2.5.1 Class 1, 5 and 6 hooks. Unless otherwise specified, type V, class 1, 5 and 6 hooks shall be manufactured from alloy steel conforming to ASTM A322, ASTM A304 or ASTM A510/A510M.

B.2.2.5.2 Class 2 and 4 hooks. Unless otherwise specified, type V, class 2 and 4 hooks shall be manufactured from carbon steel conforming to ASTM A510/A510M, ASTM A576, ASTM A920/A920M, ASTM A909/A909M, or ASTM A921/A921M.

B.2.2.5.3 Class 3 hooks. Unless otherwise specified, type V, class 3 hooks shall be manufactured from carbon steel conforming to ASTM A510/A510M, ASTM A576, ASTM A920/A920M, ASTM A909/A909M, or ASTM A921/A921M or alloy steel conforming to ASTM A322, ASTM A304 or ASTM A510/A510M.

B.2.2.6 Type VI rings. Unless otherwise specified, type VI rings shall be manufactured from alloy steel conforming to ASTM A322, ASTM A304 or ASTM A510/A510M.

B.2.2.7 Type VII swivels. Unless otherwise specified, type VII Swivels shall be manufactured from carbon steel conforming to ASTM A510/A510M, ASTM A576, ASTM A920/A920M, ASTM A909/A909M, or ASTM A921/A921M.

RR-C-271G
APPENDIX B

B.2.2.8 Type IX bead-chain fasteners. Type IX bead-chain fasteners shall be manufactured from one of these listed materials as specified in the procurement document.

- a. Steel composition at manufacturer's option
- b. CRES composition at manufacturer's option
- c. Brass composition at manufacturer's option

B.2.2.9 Type X bead-chain couplings. Type X bead-chain couplings shall be manufactured from one of these listed materials as specified in the procurement document.

- a. Steel composition at manufacturer's option
- b. CRES composition at manufacturer's option
- c. Brass composition at manufacturer's option

B.2.2.10 Type XI bead-chain insulating couplings caps. Type XI bead-chain insulating coupling caps shall be manufactured from one of these listed materials as specified in the procurement document.

- a. Steel composition at manufacturer's option
- b. CRES composition at manufacturer's option
- c. Brass composition at manufacturer's option

B.2.2.11 Type XIII pear-shaped links. Unless otherwise specified, type XIII pear-shaped links shall be manufactured from alloy steel conforming to ASTM A322, ASTM A304 or ASTM A510/A510M.

B.2.2.12 Type XIV mechanical coupling links. Unless otherwise specified, type XIV mechanical coupling links shall be manufactured from alloy steel conforming to ASTM A322, ASTM A304 or ASTM A510/A510M.

B.2.2.13 Type XV end links. Unless otherwise specified, type XV end links shall be manufactured from carbon steel conforming to ASTM A576, ASTM A920/A920M, ASTM A909/A909M, or ASTM A921/A921M or alloy steel conforming to ASTM A322, ASTM A304 or ASTM A510/A510M.

B.2.2.14 Type XVI chain master links. Unless otherwise specified, type XVI chain master links shall be manufactured from alloy steel conforming to ASTM A322, ASTM A304 or ASTM A510/A510M.

MILITARY INTERESTS:

Custodians:

Navy - SH
Air Force - 99
DLA - GS

Review Activities:

Air Force - 71
Other - DS

CIVIL AGENCY
COORDINATING ACTIVITY:

GSA - FAS

Preparing Activity:

DLA - GS5

(Project 4010-2016-002)

NOTE: The activities listed above were interested in this document as of the date of this document. Since organizations and responsibilities can change, you should verify the currency of the information above using the ASSIST database at <https://assist.dla.mil/>